

# 10

## APPLICATION OF COMMUNICATION TECHNOLOGY IN MALAYSIAN HOSPITAL

Fatimah Mohamad  
Mohd Hafiez Izzwan Bin Saad

### 10.1 INTRODUCTION

This paper reports based on the communication technology at hospital. The focus of the paper is on describing the application of communication technology in a Malaysian hospital. Communication technology in Malaysian hospital, they are connected through e-government and ehospital. Hospital in Malaysia share the database with other hospital in order to compile and updated the database by using the appropriate system like e-government and e hospital. Besides,this paper also organize five main communication in hospital, like wireless local area network(WLAN),medical local area network (MedLAN),voice over wireless local area network (VoWLAN),Real Time Location System(RTLS),and pagers.

### 10.2 E-GOVERNMENT AND E-HOSPITAL

E-Government (from electronic government, also known as e-gov, digital government, online government or in a certain context transformational government) refers to government's use of information technology to exchange information and services with citizens, businesses, and other arms of government. [1]E-Government may be applied by the legislature, judiciary, or administration, in order to improve internal efficiency, the delivery

of public services, or processes of democratic governance. [1] The primary delivery models are Government-to-Citizen or Government-to-Customer (G2C), Government-to-Business (G2B) and Government-to-Government (G2G) & Government-to-Employees (G2E).[1]In Malaysian hospital the delivery models is G2G.The most important anticipated benefits of e-government include improved efficiency, convenience, and better accessibility of public services. While e-government is often thought of as "online government" or "Internet-based government," many non-Internet "electronic government" technologies can be used in this context. [1]Some non-internet forms include telephone, fax, PDA, SMS text messaging, MMS, wireless networks and services, Bluetooth, CCTV, tracking systems, RFID, biometric identification, road traffic management and regulatory enforcement, identity cards, smart cards and other NFC applications; polling station technology (where non-online voting is being considered), TV and radio-based delivery of government services, email, online community facilities, newsgroups and electronic mailing lists, online chat, and instant messaging technologies. [1]There are also some technology-specific sub-categories of e-government, such as m-government (mobile government), u-government (ubiquitous government), and g-government (GIS/GPS applications for e-government) [1].In hospital, e-hospital also known as an 'online government to citizen' to connect between hospitals and citizen. Almost Malaysian hospital use e-hospital to keep in touch with patient, like doctor and patient to arrange an appointment for consultation and to manage the appropriate time to conduct the operation. So, with this technology, there is an option to meet the doctor through the virtual medium.

### **10.3 COMMUNICATION IN HOSPITAL**

#### **10.3.1 Wireless Local Area Network(WLAN) In Hospital.**

A wireless LAN or WLAN is a wireless local area network, which is the linking of two or more computers without using wires.

WLAN utilizes spread-spectrum or Orthogonal frequency-division multiplexing (OFDM) modulation technology based on radio waves to enable communication between devices in a limited area, also known as the basic service set[2]. This gives users the mobility to move around within a broad coverage area and still be connected to the network[2]. For the home user, wireless has become popular due to ease of installation, and location freedom with the gaining popularity of laptops[2]. Public businesses such as coffee shops or malls have begun to offer wireless access to their customers; some are even provided as a free service[2]. Large wireless network projects are being put up in many major cities[2].



**Figure 10.1** WLAN access configuration using Access Point[4]

A WLAN technology can be used for limited range service, based on the 802.11 standard and can be classified as follow:

- **802.11** -- applies to wireless LANs and provides 1 or 2 Mbps transmission in the 2.4 GHz band using either frequency hopping spread spectrum (FHSS) or direct sequence spread spectrum (DSSS)[3].
- **802.11a** -- an extension to 802.11 that applies to wireless LANs and provides up to 54 Mbps in the 5GHz band. 802.11a uses an Orthogonal Frequency Division Multiplexing (OFDM) encoding scheme rather than FHSS or DSSS[3].
- **802.11b** -- an extension to 802.11 that applies to wireless LANs and provides 11 Mbps transmission (with a fallback

to 5.5, 2 and 1 Mbps) in the 2.4 GHz band. 802.11b uses only DSSS[3].

- **802.11g** -- applies to wireless LANs and provides 20+ Mbps in the 2.4 GHz band[3].

The medical community continues to look for ways to maintain accuracy while improving operational efficiency [3].For instance, doctors can access and update patient information using computers at the patient's bedside instead of manually keeping charts that are kept either at the bedside or nurses station[3].Equipment used to monitor patient wellbeing can be hard-wired to the nurses station to provide remote access to vital data[3].It is easy to see that the trend toward the use of technology in managing patient care is beneficial[3].Yet concern is often expressed over using wireless technology to advance operational efficiency.[3]Interference—an issue associated with the use of multiple emitters within the same spectrum—seems to obscure perceptions of data-link reliability[3].There is additional concern regarding the perceived complexity of implementing a wireless solution[3].The challenge of network planning, tracking the use of users and technology, and debugging (when things fail to work) can inhibit the use of an unseen radio link to replace a hardwired connection[3].Medical equipment used to monitor a patient is typically mobile and can be readily moved anywhere along with the patient.[3]

Typically, such equipment is disconnected and reconnected via hardwire to each network-equipped room every time the patient is moved[3].If the monitoring equipment has a wireless capability, on the other hand, connections can be managed automatically by the equipment itself—making the device truly mobile[3].Medical telemetry, which is used to monitor ambulatory patients while they move about, can be easily managed with wireless systems[3].

### **10.3.2 Medical Local Area Network (Medlan) System**

In hospital, MedLAN system is using for WLAN[5]. MedLAN has become an important thing to communicated[5]. The system will built in order to connect throughout all the devices such as computer, laptop, personal digital assistant (PDA), cell phone and others[5]. Recently the concept of MedLAN systems dedicated to application scenarios for wireless local area networks (WLAN) in hospital A&E departments has been presented[5]. An essential element in the acceptance of the system will be reassuring all stakeholders in the system that data transmitted using the system is secure[5]. In order for the stakeholders to be reassured technical and managerial issues have to be addressed[5]. Technical issues to be addressed include selection of a suitable encryption algorithm with a 128-bit key for encrypting the wireless links and identification of a suitable crypto-board to be fitted to the system laptop computers[5]. In many respects the managerial issues pose bigger challenges than the technical issues[5]. Where the MedLAN system is being introduced members of the E-MED Systems Research Group will have to liaise with hospital managers to establish how the hospital's data security-policy can be expanded to accommodate the E-Med system and the cost implications of this expansion determined[5]. The cost of insuring the security of the data handled by the MedLAN system will have to be determined[5].

The current system's design and research methodology is divided into three main tasks representing the pyramid development procedures of such application:

- Modeling and simulation studies to define the biomedical digital signal processing requirements for internetworking operational modes with 2G and 3G mobile systems[Figure 2]
- System hardware and software design to implement a mobile MedLAN system capable of transmitting several channels of medical data and information[5].

- Clinical testing and evaluation of the prototype MedLAN model, radio link and data acquisition server[5].

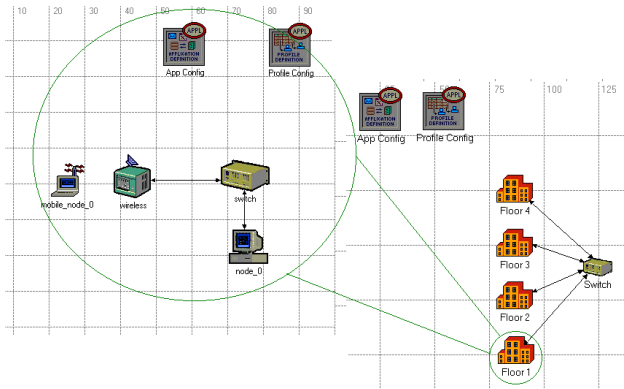

**Figure 10.2** MedLAN model using OPNET Modeler [5]

Figure 10.2 shows the model created [5].It consists of a wireless node (mobile\_node\_0) that represents the laptop computer that roams around the A&E ward, an access point that will probably be placed in the centre of the ceiling of the A&E ward (wireless), a fast switch responsible for distributing the data (switch) and a desktop computer (node\_0) that will be placed in the consultant’s office[5].All the possible applications that the units can use, are stored within “App Config” while the settings for the applications that were used in this specific model, are within “Profile Config”[5].Overall, the modeling of the system produced encouraging results, proving the feasibility of the MedLAN project[5].A schematic of the MedLAN system, is shown in Figure 3[5].It consists of the two main parts:

- The mobile trolley that exists in the Accident & Emergencies ward (A&E) and the consultation point, within the hospital[5].
- The mobile trolley consists of a high performance laptop computer that is equipped with a WLAN PCMCIA card (initially using the IEEE802.11b protocol) that will permit total mobility within the A&E room and beyond[5]. An access point within the A&E room, acts as a transiver for the network data to be transmitted to and received from the rest of the network structure[5]. A high quality digital camcorder is connected to the laptop and with the use of the IEEE1394 protocol, high-resolution video and audio is transmitted[5]. Additional medical instruments (like otoscopes, dermoscopes etc) are also connected to the laptop providing a lowweight compact roaming system[5]. It is expected that the weight of the contents of the mobile trolley would not exceed 4 kg[5].

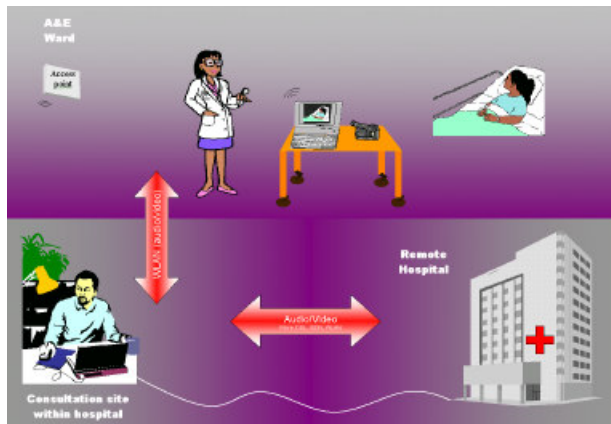

**Figure10.3** Schematic of the MedLAN system[5]

In the consultation point (that can be at any location within the hospital) the consulting physician can have a choice of teleconferencing either from a fixed computer within the existing hospital network, or a mobile laptop, sharing the same mobility

advantages as the former laptop[5].It will even be capable of transmitting video to a PDA pocketsize computer [Figure 10.4], thus taking advantage of the recent developments in PDAs[5].This way (and by placing additional access points to the general area where the consulting doctor would be),the doctor can move around the area while only carrying a 200 gr PDA[5].The PDA will be equipped with a PCMCIA card and it would be able just to receive video[5].

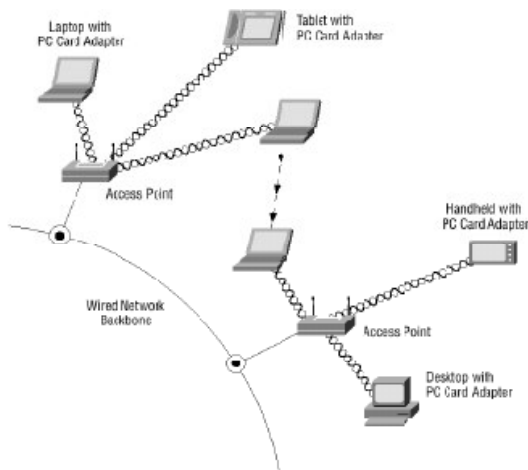

**Figure10.4** Schematic of the MedLAN system[5].

### **10.3.3 VoWLAN(Voice of WLAN)**

VoWLAN (Voice over Wireless LAN) is the use of a wireless broadband network for the purpose of vocal conversation[6].In other words, it's just like VOIP but over a Wi-Fi network[6].VoWLAN can be conducted over any Internet accessible device, including a laptop, PDA or the new VoWLAN units which look and function like cellphones.

VoWLAN's chief advantages to consumers are cheaper local and international calls, free calls to other VoWLAN units and



a simplified integrated billing of both phone and Internet service providers[6].Although VoWLAN and 3G have certain feature similarities, VoWLAN is different in the sense that it uses a wireless internet network (typically 802.11) rather than a Cellular network[6].Both VoWLAN and 3G are used in different ways[6].For example, a company with fixed warehouses or locations would take advantage of their existing WiFi network and use VoIP(hence VoWLAN) for employees to communicate with one another[6].This system can also be used like Land Mobile Radio System or Walkietalkie systems with push to talk and emergency broadcast channels[6].Non-VoWLAN Solution: Another example would be a company that has mobile workers very much like the FedEx delivery person or the CocaCola delivery driver who delivers goods to a store[6].These workers need to take advantage of 3G type services whereby a cellular company (like Cingular, Verizon, T-Mobile, Sprint/Nextel) provide data access between the handheld device and the companies backend network[6].Voice over WLAN (VoWLAN) technology was selected to boost the effectiveness of communications at hospital[6].It is important for the staff, nurses,doctors and patients were craving a more efficient system to keep everyone in touch[6].Under the original system, nurses typically had to go to the main desk on the floor, phone or page a doctor, and wait at the desk for a response which could take a few minutes or much longer[6].Likewise, if a nurse did not wait for a response when the doctor returned the call, the nurse would have to be paged to the front desk or physically tracked down while the doctor waited on the phone[6].

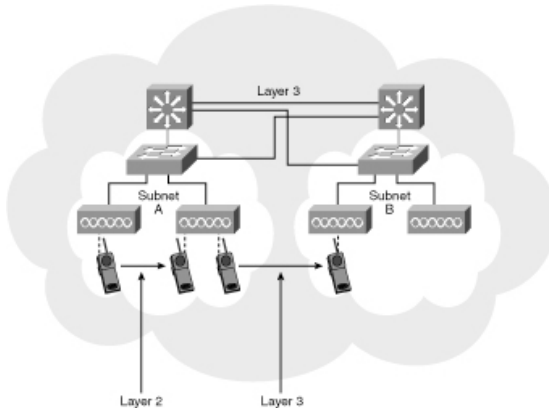
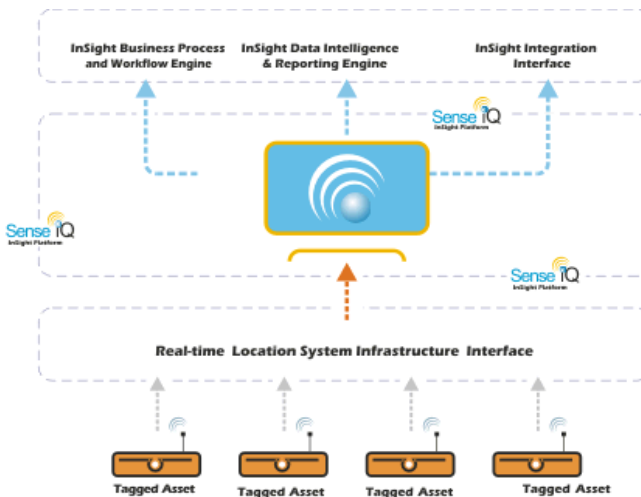

Fig 10.5 VoWLAN systems[7]

#### 10.3.4 RTLS (Real Time Location System)

Real Time Locating Systems (RTLS), incorrectly named Real Time Location Systems, are used to track and identify the location of objects in real time using simple, inexpensive nodes (badges/tags) attached to or embedded in objects and devices (readers) that receive the wireless signals from these tags to determine their locations[8]. RTLS typically refers to systems that provide passive (automatic) collection of location information[8]. RTLS let hospitals and other healthcare organizations synchronize workflows, reduce inventories, and increase patient throughput. At the same time, staff satisfaction and safety are remarkably improved neither for the patient's health. Using of RTLS systems, can locate an object relative to a set of antennas placed in particular positions that form the reference coordinates[9]. For example, if the broadcast from an RFID tag is read by three different antennas at a particular time, their position relative to those three receiver antennas will give the location of the corresponding object[9]. Since this is a continuous process, the location of objects and personnel at any given point of time can be tracked[9]. In healthcare, RTLS helps in locating healthcare personnel in an emergency, tracking movement of patients for

effective throughput management and patient safety, alleviating security concerns by monitoring unauthorized access to neonatal nurseries in hospitals, monitoring if sensitive data disks are in the possession of unauthorized personnel or in unauthorized areas, tracking expensive equipment like infusion pumps to minimize location time and for better inventory control thereby reducing rental and purchasing costs etc[9]. Other uses of RTLS in healthcare include process flow enhancement to maximize bed turn over rates and increase throughput in operating rooms by prompt location of equipment and personnel[9]. According to a Frost Sullivan report, studies and pilot programs have shown a decrease in length of hospital stay by over 20 % and bed turnover rates of less than 10 minutes upon RTLS installation[9]. This could potentially decrease patient wait time and emergency room stay significantly[9]. Implementation of RTLS was found to provide a substantial return on investment for organizations in the range of 100% to 150% in some pilot installations[9].



**Figure 10.6** Connection of RTLS[10]

### **10.3.5 Pager**

Another device use in hospital is Pager[11].A pager (sometimes called a beeper) is a simple personal telecommunications device for short messages[11].A one-way numeric pager can only receive a message consisting of a few digits, typically a phone number that the user is then expected to call[11].Alphanumeric pagers are also available, and twoway ones can send email or SMS messages as well as receiving[11].Until the popular adoption of mobile phones in the late 1990s, pagers fulfilled the role of common personal and mobile communications[11].As of 2007, pagers have fallen into obsolescence and are preserved only by niche markets consisting largely of emergency service personnel, medical personnel, and information technology support staff[11].Paging was invented by Multitone Electronics in 1956 at St Thomas' Hospital in London to alert doctors attending emergencies[11].Since then, paging has evolved in sophistication[11].Today, millions of messages are transmitted to people needing fast, reliable messaging communications[11].In the world of paging there are two distinct categories of system in operation[11].There are on-site paging systems that are used in hospitals to convey the same urgent information as when they were invented in 1956[11].The other type is wide area paging, which offers similar features as on-site paging, but provides the radio coverage across a city, region or country rather than in just one hospital building[11].Originally operating on AM radio frequencies, paging moved to FM schemes prior to becoming a ubiquitous form of communications around the developed and developing world[11].In some cases, before the advent of cellular phone systems the pager was used as a replacement for a lack of cheap local or international phone services[11].



**Fig 10.7** Pager use in hospital[12]

#### **10.4 CONCLUSION**

Recently the concept of communication technology systems in Malaysian hospital dedicated to application for wireless local area network(WLAN),medical local area network (MedLAN),voice over wireless local area network (VoWLAN),Real Time Location System(RTLS),and Pagers.

#### **REFERENCES**

- [1] <http://en.wikipedia.org/wiki/E-government> (25 February 2008)
- [2] [http://en.wikipedia.org/wiki/Wireless\\_LAN](http://en.wikipedia.org/wiki/Wireless_LAN) (25 February 2008))
- [3] <http://www.devicelink.com/mddi/archive/03/07/001.html> (25 February 2008)
- [4] <http://www.pkukmweb.ukm.my> (25 February 2008)
- [5] [users.hol.gr/~bany/IJMM%20application%20of%20MedLAN.pdf](http://users.hol.gr/~bany/IJMM%20application%20of%20MedLAN.pdf) (25 February 2008)
- [6] <http://en.wikipedia.org/wiki/VoWLAN> (25 February 2008)
- [7] [www.isp-planet.com/.../2007/cisco\\_vowlans.html](http://www.isp-planet.com/.../2007/cisco_vowlans.html) (25 February 2008)
- [8] [http://en.wikipedia.org/wiki/Real\\_time\\_location\\_system](http://en.wikipedia.org/wiki/Real_time_location_system) (25 February 2008)
- [9] <http://www.healthnewsdirect.com/?p=60> (25 February 2008)

- [10] [www.senseiq.com/products.asp](http://www.senseiq.com/products.asp) (25 February 2008)
- [11] <http://en.wikipedia.org/wiki/Pager> (25 February 2008)
- [12] <http://www.horizonwireless.com.au/pagers.php> (25 February 2008)