

PERFORMANCE OF SERIALY CONCATENATED CHANNEL CODING WITH SPACE TIME BLOCK CODING IN OFDM TRANSMISSION SYSTEMS

MULADI¹, N. FISAL² & S. K. YUSOF³

Abstract. It is well known that space-time diversity using space-time coding (STC) is an effective technique to improve wireless communication performance. STC was designed for flat fading channel and consists of space-time trellis code (STTC) and space-time block code (STBC). STTC has provided diversity gain and coding gain in the cost of decoding complexity. On the other hand, STBC only provides diversity gain but simple in decoding complexity. Thus, in this paper, we proposed serially concatenated Bose-Chaudhuri Hocquengheim (BCH) code with STBC from orthogonal design (STBC-OD) scheme to provide diversity gain and also coding gain in the system. We incorporated OFDM transmission system onto our proposed scheme to maintain the performance over multipath selective fading channels. Performance of the system was investigated when M-ary phase shift keying (M-PSK) modulation was used for full-rate, half-rate, and three quarter-rate of transmission employing appropriate number of transmit antennas. Simulation results showed that the proposed system has improved the SNR gain over the related uncoded schemes. Channel state information was assumed available at the receiver.

Keywords: BCH, STBC-OD, OFDM

Abstrak. Telah diketahui bahawa kepelbagaian ruang-masa dengan menggunakan kodan ruang-masa (STC) adalah satu teknik yang berkesan dalam memperbaiki prestasi perhubungan wayarles. STC direka untuk saluran pemudaran rata dan ia terdiri daripada kodan trellis ruang-masa (STTC) dan kodan blok ruang-masa (STBC). STTC boleh memberikan gandaan kepelbagaian dan gandaan pengkodan dengan melibatkan kos dari segi kekompleksan nyahkodan. Sebaliknya, STBC hanya membekalkan gandaan kepelbagaian tetapi mengurangkan kekompleksan nyahkodan. Dalam kertas kerja ini, kami membentangkan skema kod Bose-Chaudhuri Hocquengheim (BCH) siri terangkai dengan STBC daripada rekaan ortogon (STBC-OD) untuk mendapatkan gandaan kepelbagaian dan juga gandaan pengkodan dalam sistem ini. Kami juga melibatkan sistem penghantaran OFDM dalam skema yang dibentangkan untuk mengekalkan prestasi pada saluran pudaran memilih berbilang-laluan. Prestasi sistem ini diselidiki apabila pemodulatan penguncian anjakan fasa pada kadar-penuh, kadar-separuh, dan kadar-3/4 dengan menggunakan bilangan antena penghantar yang bersesuaian. Keputusan penyelakuan menunjukkan bahawa system yang dibentangkan ini dapat memperbaiki gandaan SNR berbanding dengan skema tidak terkod yang berkaitan. Maklumat keadaan saluran dianggap boleh sedia ada di penerima.

Kata kunci: BCH, STBC-OD, OFDM

^{1,2&3} Department of Telematics and Optical Communication, Faculty of Electrical Engineering, Universiti Teknologi Malaysia, 81310 UTM Skudai, Johor Darul Takzim, Malaysia

1.0 INTRODUCTION

The demand of capacity in cellular and wireless local area network has grown in a literally exclusive manner during the last decade. In particular, the need of wireless Internet access and multimedia applications require an increase in information throughput with orders of magnitude compared to the data rates. However, wireless communication systems faced two major impairments as attenuation due to multipath in the propagation media and interference from other users. These problem have led to the development of multi-carrier transmission system. The most famous type of multi-carrier system is Orthogonal Frequency Division Multiplexings (OFDM), capable of delivering high data rate over multi-path fading channel and combating inter-symbol interference (ISI) [1].

To increase the channel capacity, OFDM employ multiple antennas both at transmitter and receiver to perform the multiple input multiple output (MIMO) system [2]. Multiple antenna system can also combat channel impairment due to moving vehicle. Application of coding technique in MIMO system provides diversity in space and time that can introduce robust performance. Transmit diversity employing multiple antennas at the receiver combined with coding technique is a novel scheme to combat fading [3]. Recently, space-time trellis coding (STTC) has been introduced in [4] and space-time block coding (STBC) in [5, 6] and their performance was investigated in [7]. These space-time coding technique were designed for flat fading channel and thus they are appropriate to work with OFDM system for frequency-selective fading channel since OFDM signals transform frequency selective fading channel to flat-fading channels. STTC provides diversity and coding gain but STBC provides diversity gain and very little or no coding gain. Maximizing the rank criterion of STTC will achieve maximum diversity gain of STTC and maximizing determinant criterion will maximize coding gain. However, for a fixed number of transmit antennas, STTC decoding complexity increases exponentially with the transmission rate. The decoding complexity is a challenging issue in space-time coding applications [8].

STBC, on the other hand, has simple decoding process with no coding gain. Thus it is highly recommended to use them in conjunction with channel coding. The advantage is that the design of the channel code that provides coding gain and the code which provides diversity is separated in the concatenated system, unlike the STTC [4]. From a practical viewpoint, this configuration is attractive because it requires only a small modification to the transmitter or receiver, and for that reason, it has been considered for inclusion in the WCDMA standard [9]. At the receiver, the optimal decoder can be constructed by concatenating of separate decoders.

In this work, we investigated the performance of serially concatenated channel block coding with STBC in OFDM transmission systems. In particular, Bose-Chauduri-Hocquenghem (BCH) was used as channel block coding which also has simple decoding. The transmitter uses two, three and four transmit antennas and combines it with the STBC from orthogonal design (STBC-OD) in [10] to provide diversity in

space and time. The system obtains the transmission rate of one, half and three quater symbols/sec/Hz.

2.0. SYSTEM MODEL

The proposed system employs N_T transmit antennas and N_R receive antennas as depicted in Figure 1. A stream binary bit of information is generated randomly is assumed equiprobable, then encoded using a BCH channel block coding. The coded binary data then attempt to column-filling and in-row transmitting matrix interleaved in order to span the channel memory effect. Bit to symbol conversion transforms the coded binary data to M elements of modulo- M symbols using Gray mapping prior to mapping into M -ary PSK constellations and then converted into N parallel form. The l -th block of data is denoted as:

$$S_l = \{s(lN), s(lN + 1), \dots, s(lN + N - 1)\} \tag{1}$$

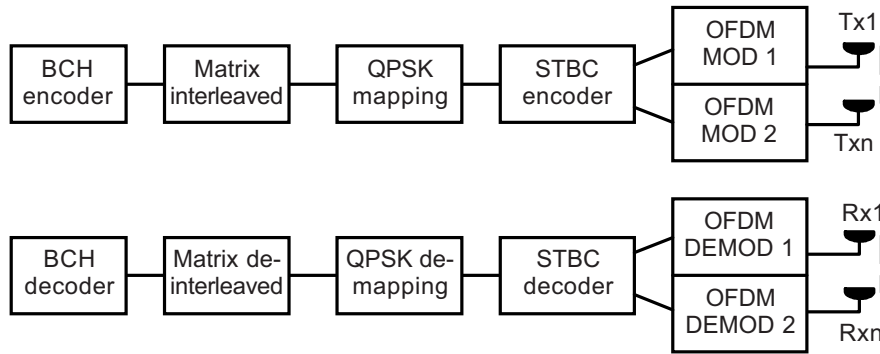

Figure 1 Proposed system

STBC-OD is defined by a (TxN_T) transmission matrix $\mathcal{G}_{N_T,T}$ given by,

$$\mathcal{G}_{N_T,T} = \begin{bmatrix} g_{1,1} & g_{1,2} & \dots & g_{1,N_T} \\ g_{2,1} & g_{2,2} & \dots & g_{2,N_T} \\ \vdots & \vdots & \ddots & \vdots \\ g_{T,1} & g_{T,2} & \dots & g_{T,N_T} \end{bmatrix} \tag{2}$$

where each of elements $g_{i,j}$ is a linear combination of a subset of element of S_l and their conjugates, N_T is the number of transmission antennas and T is the symbol period of STBC-OD system. In order to utilize the space-frequency diversity, the input blocks for OFDM at each transmit antenna should have the length of N . STBC-OD

provides N_T blocks: $S'_1, S'_2, \dots, S'_{N_T}$ of the length N , each consisting of N/T sub-blocks, i.e.,

$$\mathbf{S}_i = [\mathbf{s}_{i,0} \quad \mathbf{s}_{i,1} \quad \dots \quad \mathbf{s}_{i,N-1}]^T, \quad (i = 1, 2, \dots, N_T) \quad (3)$$

where $[\cdot]^T$ is matrix transpose. OFDM modulators generate blocks with length N :

$$\mathbf{X}_1, \mathbf{X}_2, \dots, \mathbf{X}_{N_T} \quad (4)$$

that corresponds to \mathbf{S}_i , where they will be transmitted by first, second, ... and N_T -th transmit antennas, respectively. Assuming that the guard time interval is longer than the largest delay spread of the multipath channel to avoid intersymbol interference, the received signal will be the convolution of the channel response and the transmitted signal. It is also assumed that the channel is static during one OFDM block. At the j -th receiver antenna, at the receiver after removing the cyclic prefix, the FFT output can be stated as:

$$\mathbf{R}_j = \sum_{i=1}^{N_T} \mathbf{H}_{ij} \mathbf{S}_i + \mathbf{W}_j \quad (5)$$

where

$$\mathbf{R}_j = [r_{j,0} \quad r_{j,1} \quad \dots \quad r_{j,N-1}]^T, \quad (j = 1, 2, \dots, N_R) \quad (6)$$

which $r_{j,n}$ is the received signal at the received antenna j at time n . and \mathbf{H}_{ij} represents a three-dimensional matrix whose elements:

$$(H_{i,j,k}, i = 1, 2, \dots, N_T \quad j = 1, 2, \dots, N_R \quad k = 0, 1, 2, \dots, N-1) \quad (7)$$

are FFT of the frequency response of the channel $h_{i,j,k}$ and $\mathbf{W}_j = [W_0, \dots, W_{N-1}]^T$ denotes the AWGN experienced by j -th receive antenna.

Assuming that the channel state information is known at the receiver, the *maximum-likelihood* (ML) algorithm can be used for STBC-OD decoding of the received signal, which is only a linear processing. Using a coherent detection, the receiver decodes the received signals to recover the transmitted symbols. The detected symbol is:

$$\tilde{s}_k = \sum_{j=1}^{N_R} \sum_{i=1}^{N_T} \sum_{t=1}^T H_{i,j,Tk} r_{i,j,k} \quad (8)$$

and then receiver uses ML algorithm to obtain the received symbol s_k based on the following decision:

$$\begin{aligned}
s_k &= \min_{s \in \mathcal{A}} \|\tilde{s}_k - s\|^2 \\
&= \min_{s \in \mathcal{A}} \left((\tilde{s}_k - s)(\tilde{s}_k^* - s^*) \right)
\end{aligned} \tag{9}$$

that performed over all symbol $s \in \mathcal{A}$, where \mathcal{A} is a set of the constellation components.

After symbol to bit conversion, block \mathbf{s}_k , $k = 0, 1, \dots, N-1$, is de-interleaved and then sent to the outer decoder, particularly BCH decoder. Detail elaboration and illustration of STBC-OD that provide transmission of full rate, half rate and three quarter rates are presented in the next sub-sections.

2.1 Full Rate of Transmission

Full rate of transmission using STBC-OD only is provided by employing two transmit antennas. The corresponding matrix code for two transmit antennas is \mathcal{G}_{22} [6], which can be written as follows:

$$\begin{aligned}
\mathcal{G}_{22} &= \begin{bmatrix} s_k & s_{k+1} \\ -s_{k+1}^* & s_k^* \end{bmatrix} \\
&= \begin{bmatrix} \mathbf{s}_{1,k} & \mathbf{s}_{2,k} \end{bmatrix}
\end{aligned} \tag{10}$$

where $*$ is complex-conjugate, $k = 0, \dots, \frac{N}{T} - 1$, and sub-blocks of $\mathbf{s}_{1,k}$ and $\mathbf{s}_{2,k}$ are:

$$\mathbf{s}_{1,k} = \begin{bmatrix} s_{2k} & -s_{2k+1}^* \end{bmatrix}^T, \quad \mathbf{s}_{2,k} = \begin{bmatrix} s_{2k+1} & s_{2k}^* \end{bmatrix}^T \tag{11}$$

Then two blocks, \mathbf{S}_1 and \mathbf{S}_2 of the length N are provided as follows:

$$\mathbf{S}_1 = \begin{bmatrix} s_{1,0} & s_{1,1} & \dots & s_{1,\frac{N}{2}-1} \end{bmatrix}^T, \quad \mathbf{S}_2 = \begin{bmatrix} s_{2,0} & s_{2,1} & \dots & s_{2,\frac{N}{2}-1} \end{bmatrix}^T \tag{12}$$

Next, OFDM modulator generates blocks \mathbf{X}_1 and \mathbf{X}_2 correspond to \mathbf{S}_1 and \mathbf{S}_2 , that will be transmitted simultaneously by the first and second transmit antennas, respectively. Cyclic prefix symbols with appropriated-length are inserted into the blocks to combat intersymbol interference at the channel.

The received signal at the j -th receive antenna after removing cyclic prefix and OFDM demodulation can be written as follows:

$$\mathbf{R}_j = \mathbf{H}_{1j}\mathbf{S}_1 + \mathbf{H}_{2j}\mathbf{S}_2 + \mathbf{W}_j \tag{13}$$

The combiner collects the received signals from all receive antennas and compute the received symbols using the following equations:

$$\begin{aligned}
\tilde{s}_{2k} &= \sum_{j=1}^{N_R} H_{1,j,2k}^* r_{1,j,k} + H_{2,j,2k}^* r_{2,j,k} \\
\tilde{s}_{2k+1} &= \sum_{j=1}^{N_R} H_{2,j,2k+1}^* r_{1,j,k} - H_{1,j,2k+1}^* r_{2,j,k}
\end{aligned} \tag{14}$$

where

$$r_{1,j,k} = r_{j,2k}, \quad r_{2,j,k} = r_{j,2k+1} \tag{15}$$

The above decision variables provide a diversity gain of order two for every s_{2k} and s_{2k+1} . The received symbols are obtained by using the decision rule in Equation (9). Then, the decoded signals will proceed in outer decoder that is BCH decoder. The simplified decoding algorithm of Equation (14) is presented in detail in Appendix 1.

2.2 Half Rate of Transmission

Half rate transmission can be acquired by employing three or four transmit antennas combined with its correspond matrix code \mathcal{G}_{38} and \mathcal{G}_{48} , respectively. Here, we derive the half rate of transmission by employing four transmit antennas, relied on the fact that it is easier to perform than for the three transmit antennas. Furthermore, the results can be generalized for three transmit antennas and using matrix code \mathcal{G}_{38} .

Let us consider an STBC-OD for four transmit antennas ($N_T=4$) using a code \mathcal{G}_{48} [6], given by:

$$\mathcal{G}_{48} = \begin{bmatrix} S_{4k} & S_{4k+1} & S_{4k+2} & S_{4k+3} \\ -S_{4k+1} & S_{4k} & -S_{4k+3} & S_{4k+2} \\ -S_{4k+2} & S_{4k+3} & S_{4k} & -S_{4k+1} \\ -S_{4k+3} & -S_{4k+2} & -S_{4k+1} & S_{4k} \\ S_{4k}^* & S_{4k+1}^* & S_{4k+2}^* & S_{4k+3}^* \\ -S_{4k+1}^* & S_{4k}^* & -S_{4k+3}^* & S_{4k+2}^* \\ -S_{4k+2}^* & S_{4k+3}^* & S_{4k}^* & -S_{4k+1}^* \\ -S_{4k+3}^* & -S_{4k+2}^* & S_{4k+1}^* & S_{4k}^* \end{bmatrix} \tag{16}$$

which can be written as:

$$\mathcal{G}_{48} = [\mathbf{s}_{1,k} \ \mathbf{s}_{2,k} \ \mathbf{s}_{3,k} \ \mathbf{s}_{4,k}], \quad (k = 0, 1, \dots, \frac{N}{8} - 1) \tag{17}$$

where

$$\begin{aligned}
 \mathbf{s}_{1,k} &= \left[s_{4k} - s_{4k+1} - s_{4k+2} - s_{4k+3} \ s_{4k}^* - s_{4k+1}^* - s_{4k+2}^* - s_{4k+3}^* \right]^T \\
 \mathbf{s}_{2,k} &= \left[s_{4k+1} \ s_{4k} \ s_{4k+3} - s_{4k+2} \ s_{4k+1}^* \ s_{4k}^* \ s_{4k+3}^* - s_{4k+2}^* \right]^T \\
 \mathbf{s}_{3,k} &= \left[s_{4k+2} - s_{4k+3} \ s_{4k} - s_{4k+1} \ s_{4k+2}^* - s_{4k+3}^* - s_{4k}^* - s_{4k+1}^* \right]^T \\
 \mathbf{s}_{4,k} &= \left[s_{4k+3} \ s_{4k+2} - s_{4k+1} \ s_{4k} \ s_{4k+3}^* \ s_{4k+2}^* - s_{4k+1}^* \ s_{4k}^* \right]^T
 \end{aligned} \tag{18}$$

It can be seen that STBC-OD will send four symbols in eight times symbol resulting in half transmission rate.

Four blocks, \mathbf{S}_i , $i = 1, 2, 3, 4$ are provided by matrix code \mathcal{G}_{48} as follows:

$$\mathbf{S}_i = \left[s_{i,0} \quad s_{i,1} \quad \cdots \quad s_{i, \frac{N}{8}-1} \right]^T, \quad (i = 1, 2, 3, 4) \tag{19}$$

OFDM modulator generates four blocks, \mathbf{X}_1 , \mathbf{X}_2 , \mathbf{X}_3 and \mathbf{X}_4 related to \mathbf{S}_1 , \mathbf{S}_2 , \mathbf{S}_3 and \mathbf{S}_4 that are transmitted through first, second, third and fourth antennas respectively.

The received signal at the j -th receive antenna after cyclic prefix removing and OFDM demodulation is:

$$\mathbf{R}_j = \mathbf{H}_1 \mathbf{S}_1 + \mathbf{H}_2 \mathbf{S}_2 + \mathbf{H}_3 \mathbf{S}_3 + \mathbf{H}_4 \mathbf{S}_4 + \mathbf{W}_j \tag{20}$$

These received signals from all receive antennas are combined in the combiner and the estimated values of the transmitted symbols are computed as follows:

$$\begin{aligned}
 \tilde{s}_{4k} &= \sum_{j=1}^{N_R} \left\{ \begin{aligned} &H_{1,j,8k}^* r_{1,j,k} + H_{2,j,8k}^* r_{2,j,k} + H_{3,j,8k}^* r_{3,j,k} + H_{4,j,8k}^* r_{4,j,k} \\ &+ H_{1,j,8k}^* r_{5,j,k} + H_{2,j,8k}^* r_{6,j,k} + H_{3,j,8k}^* r_{7,j,k} + H_{4,j,8k}^* r_{8,j,k} \end{aligned} \right\} \\
 \tilde{s}_{4k+1} &= \sum_{j=1}^{N_R} \left\{ \begin{aligned} &H_{2,j,8k}^* r_{1,j,k} - H_{1,j,8k}^* r_{2,j,k} - H_{4,j,8k}^* r_{3,j,k} - H_{3,j,8k}^* r_{4,j,k} \\ &+ H_{2,j,8k}^* r_{5,j,k} - H_{1,j,8k}^* r_{6,j,k} - H_{4,j,8k}^* r_{7,j,k} - H_{3,j,8k}^* r_{8,j,k} \end{aligned} \right\} \\
 \tilde{s}_{4k+2} &= \sum_{j=1}^{N_R} \left\{ \begin{aligned} &H_{3,j,8k}^* r_{1,j,k} + H_{4,j,8k}^* r_{2,j,k} - H_{1,j,8k}^* r_{3,j,k} - H_{2,j,8k}^* r_{4,j,k} \\ &+ H_{3,j,8k}^* r_{5,j,k} + H_{4,j,8k}^* r_{6,j,k} - H_{1,j,8k}^* r_{7,j,k} - H_{2,j,8k}^* r_{8,j,k} \end{aligned} \right\} \\
 \tilde{s}_{4k+3} &= \sum_{j=1}^{N_R} \left\{ \begin{aligned} &H_{4,j,8k}^* r_{1,j,k} - H_{3,j,8k}^* r_{2,j,k} + H_{2,j,8k}^* r_{3,j,k} - H_{1,j,8k}^* r_{4,j,k} \\ &+ H_{4,j,8k}^* r_{5,j,k} - H_{3,j,8k}^* r_{6,j,k} + H_{2,j,8k}^* r_{7,j,k} - H_{1,j,8k}^* r_{8,j,k} \end{aligned} \right\}
 \end{aligned} \tag{21}$$

where

$$r_{i,k} = r_{8k+i-1} \quad (22)$$

where $k = 0, 1, \dots, \frac{N}{8} - 1$, $i = 1, 2, \dots, 8$. The ML detector assumes that the channel state information is known at the receiver and uses the decision rule in Equation (9) to recover the transmitted symbols. We also assume that the channel response of eight adjacent subchannels are approximately equal, i.e. $H_{1,8k+q} = H_{1,8k}$, $H_{2,8k+q} = H_{2,8k}$, $H_{3,8k+q} = H_{3,8k}$ for $q = 0, 1, \dots, 7$.

When transmitter employs three transmit antennas and requires half rate of transmission, the corresponding STBC-OD is \mathcal{G}_{38} [6], which is defined by:

$$\mathcal{G}_{38} = \begin{bmatrix} s_{3k} & s_{3k+1} & s_{3k+2} \\ -s_{3k+1} & s_{3k} & -s_{3k+3} \\ -s_{3k+2} & s_{3k+3} & s_{3k} \\ -s_{3k+3} & -s_{3k+2} & s_{3k+1} \\ s_{3k}^* & s_{3k+1}^* & s_{3k+2}^* \\ -s_{3k+1}^* & s_{3k}^* & -s_{3k+3}^* \\ -s_{3k+2}^* & s_{3k+3}^* & s_{3k}^* \\ -s_{3k+3}^* & -s_{3k+2}^* & s_{3k+1}^* \end{bmatrix} \quad (23)$$

It is seen that \mathcal{G}_{38} can be obtained from \mathcal{G}_{48} by deleting the right-most column and the results consist of four transmitted symbols which are transmitted in $T = 8T_s$. Thus, the transmission rate remains half. The impact of deleting the right most column of \mathcal{G}_{48} to obtain \mathcal{G}_{38} are the absence of all fourth column elements of \mathcal{G}_{48} in the received signals in Equation (21). We have:

$$\begin{aligned} \tilde{s}_{3k} &= \sum_{j=1}^{N_R} \begin{pmatrix} H_{1,j,8k}^* r_{1,j,k} + H_{2,j,8k}^* r_{2,j,k} + H_{3,j,8k}^* r_{3,j,k} \\ + H_{1,j,8k}^* r_{5,j,k} + H_{2,j,8k}^* r_{6,j,k} + H_{3,j,8k}^* r_{7,j,k} \end{pmatrix} \\ \tilde{s}_{3k+1} &= \sum_{j=1}^{N_R} \begin{pmatrix} H_{2,j,8k}^* r_{1,j,k} - H_{1,j,8k}^* r_{2,j,k} + H_{3,j,8k}^* r_{4,j,k} \\ + H_{2,j,8k}^* r_{5,j,k} - H_{1,j,8k}^* r_{6,j,k} + H_{3,j,8k}^* r_{8,j,k} \end{pmatrix} \\ \tilde{s}_{3k+2} &= \sum_{j=1}^{N_R} \begin{pmatrix} H_{3,j,8k}^* r_{1,j,k} - H_{1,j,8k}^* r_{3,j,k} - H_{2,j,8k}^* r_{4,j,k} \\ + H_{3,j,8k}^* r_{5,j,k} + H_{1,j,8k}^* r_{7,j,k} + H_{2,j,8k}^* r_{8,j,k} \end{pmatrix} \\ \tilde{s}_{3k+3} &= \sum_{j=1}^{N_R} \begin{pmatrix} -H_{3,j,8k}^* r_{2,j,k} + H_{2,j,8k}^* r_{3,j,k} - H_{1,j,8k}^* r_{4,j,k} \\ -H_{3,j,8k}^* r_{6,j,k} + H_{2,j,8k}^* r_{7,j,k} - H_{1,j,8k}^* r_{8,j,k} \end{pmatrix} \end{aligned} \quad (24)$$

The simplified version of Equations (21) and (24) are presented in Appendix 1.

2.3 The Three Quarter Rate of Transmission

Multiple transmit antennas system can also provide quarter transmission rate when it employs three or four transmit antennas, and uses its correspond matrix codes \mathcal{G}_{34} and \mathcal{G}_{44} , respectively. We follow the description at the previous sub-section to present the explanation of the three quarter transmission rate. It is easier to understand when we start with employing four transmit antennas and then derive the encoding and decoding process for three transmit antennas.

The matrix code \mathcal{G}_{44} , which is STBC-OD for four transmit antennas ($N_T = 4$), is defined by [6] as:

$$\mathcal{G}_{44} = \begin{bmatrix} s_{4k} & s_{4k+1} & \frac{1}{2}\sqrt{2}s_{4k+2} & \frac{1}{2}\sqrt{2}s_{4k+2} \\ -s_{4k+1}^* & s_{4k}^* & \frac{1}{2}\sqrt{2}s_{4k+2} & \frac{1}{2}\sqrt{2}s_{4k+2} \\ \frac{1}{2}\sqrt{2}s_{4k+2}^* & \frac{1}{2}\sqrt{2}s_{4k+2}^* & \frac{1}{2}(-s_{4k} - s_{4k}^* + s_{4k+1} - s_{4k+1}^*) & \frac{1}{2}(s_{4k} - s_{4k}^* + s_{4k+1} + s_{4k+1}^*) \\ \frac{1}{2}\sqrt{2}s_{4k+2}^* & -\frac{1}{2}\sqrt{2}s_{4k+2}^* & \frac{1}{2}(s_{4k} - s_{4k}^* + s_{4k+1} + s_{4k+1}^*) & -\frac{1}{2}(-s_{4k} - s_{4k}^* + s_{4k+1} - s_{4k+1}^*) \end{bmatrix} \quad (25)$$

which can be written as:

$$\mathcal{G}_{44} = [\mathbf{s}_{1,k} \quad \mathbf{s}_{2,k} \quad \mathbf{s}_{3,k} \quad \mathbf{s}_{4,k}], \quad (k = 0, 1, \dots, \frac{N}{4} - 1) \quad (26)$$

where

$$\begin{aligned} \mathbf{s}_{1,k} &= [s_{4k} \quad -s_{4k+1}^* \quad \frac{1}{2}\sqrt{2}s_{4k+2}^* \quad \frac{1}{2}\sqrt{2}s_{4k+2}^*]^T \\ \mathbf{s}_{2,k} &= [s_{4k+1} \quad s_{4k}^* \quad \frac{1}{2}\sqrt{2}s_{4k+2}^* \quad -\frac{1}{2}\sqrt{2}s_{4k+2}^*]^T \\ \mathbf{s}_{3,k} &= [\frac{1}{2}\sqrt{2}s_{4k+2} \quad \frac{1}{2}\sqrt{2}s_{4k+2} \quad \frac{1}{2}(-s_{4k} - s_{4k}^* + s_{4k+1} - s_{4k+1}^*) \quad \frac{1}{2}(s_{4k} - s_{4k}^* + s_{4k+1} - s_{4k+1}^*)]^T \\ \mathbf{s}_{4,k} &= [\frac{1}{2}\sqrt{2}s_{4k+2} \quad -\frac{1}{2}\sqrt{2}s_{4k+2} \quad \frac{1}{2}(s_{4k} - s_{4k}^* + s_{4k+1} + s_{4k+1}^*) \quad -\frac{1}{2}(-s_{4k} - s_{4k}^* + s_{4k+1} - s_{4k+1}^*)]^T \end{aligned} \quad (27)$$

As shown above, $\mathbf{s}_{1,k}$, $\mathbf{s}_{2,k}$, $\mathbf{s}_{3,k}$, and $\mathbf{s}_{4,k}$ are the first, second, third and fourth column of matrix \mathcal{G}_{44} , consecutively. It can be seen that STBC-OD will send three symbols in four time symbol resulting in three quarter transmission rate.

STBC-OD provides four blocks of \mathbf{S}_i , $i = 1, 2, 3, 4$ that will be transmitted through i -th transmit antenna:

$$\mathbf{S}_i = \begin{bmatrix} s_{i,0} & s_{i,1} & \cdots & s_{i,\frac{N}{4}-1} \end{bmatrix}^T, \quad (i = 1, 2, 3, 4) \quad (28)$$

OFDM modulators generate blocks \mathbf{X}_1 , \mathbf{X}_2 , \mathbf{X}_3 and \mathbf{X}_4 correspond to \mathbf{S}_i at Equation (28) that are transmitted by first, second, third and fourth transmit antenna, respectively.

The received signal at each receive antenna after OFDM demodulation are:

$$\mathbf{r}_j = \mathbf{H}_1 \mathbf{S}_1 + \mathbf{H}_2 \mathbf{S}_2 + \mathbf{H}_3 \mathbf{S}_3 + \mathbf{H}_4 \mathbf{S}_4 + \mathbf{W}_j \quad (29)$$

The combiner collects the received signals from all receive antennas and results the estimated values of the transmitted symbols written as:

$$\begin{aligned} \tilde{s}_{4k} &= \sum_{j=1}^{N_R} \left\{ \begin{aligned} &H_{1,j,4k}^* r_{1,j,k} + H_{2,j,4k}^* r_{2,j,k} + \frac{1}{2} (H_{3,j,4k}^* - H_{4,j,4k}^*) (r_{4,j,k} - r_{3,j,k}) \\ & - \frac{1}{2} (H_{3,j,4k} + H_{4,j,4k}) (r_{3,j,k} + r_{4,j,k})^* \end{aligned} \right\} \\ \tilde{s}_{4k+1} &= \sum_{j=1}^{N_R} \left\{ \begin{aligned} &H_{2,j,4k}^* r_{1,j,k} - H_{1,j,4k}^* r_{2,j,k} + \frac{1}{2} (H_{3,j,4k}^* - H_{4,j,4k}^*) (r_{3,j,k} + r_{4,j,k}) \\ & + \frac{1}{2} (H_{3,j,4k} + H_{4,j,4k}) (-r_{3,j,k} + r_{4,j,k})^* \end{aligned} \right\} \\ \tilde{s}_{4k+2} &= \frac{1}{2} \sqrt{2} \sum_{j=1}^{N_R} \left\{ \begin{aligned} &H_{3,j,4k}^* (r_{1,j,k} + r_{2,j,k}) + H_{4,j,4k}^* (r_{1,j,k} - r_{2,j,k}) \\ & + (H_{1,j,4k} + H_{2,j,4k}) r_{3,j,k}^* + (H_{1,j,4k} - H_{2,j,4k}) r_{4,j,k}^* \end{aligned} \right\} \end{aligned} \quad (30)$$

where

$$r_{i,k} = r_{4k+i-1} \quad (31)$$

where $k = 0, 1, \dots, \frac{N}{4} - 1$, $i = 1, 2, \dots, 4$ and it assumes that the channel state information is known at the receiver. And we also assume that the channel response of eight adjacent subchannels are approximately equal, i.e. $H_{1,4k+q} = H_{1,4k}$, $H_{2,4k+q} = H_{2,4k}$, $H_{3,4k+q} = H_{3,4k}$ for $q = 0, 1, 2, 3$. The recovery received symbols are obtained using the decision rule in Equation (9).

We consider using three transmit antennas in obtaining $\frac{3}{4}$ transmission rate, the corresponding STBC-OD is \mathcal{G}_{34} [6] as shown below:

$$\mathcal{G}_{34} = \begin{bmatrix} s_{3k} & s_{3k+1} & \frac{1}{2} \sqrt{2} s_{3k+2} \\ -s_{3k+1}^* & s_{3k}^* & \frac{1}{2} \sqrt{2} s_{3k+2} \\ \frac{1}{2} \sqrt{2} s_{3k+2}^* & \frac{1}{2} \sqrt{2} s_{3k+2}^* & \frac{1}{2} (-s_{3k} - s_{3k}^* + s_{3k+1} - s_{3k+1}^*) \\ \frac{1}{2} \sqrt{2} s_{3k+2}^* & -\frac{1}{2} \sqrt{2} s_{3k+2}^* & \frac{1}{2} (s_{3k} - s_{3k}^* + s_{3k+1} + s_{3k+1}^*) \end{bmatrix} \quad (32)$$

The code above is obtained by deleting the right-most column of matrix code \mathcal{G}_{44} in Equation (25) and we found that there are three symbols transmitted in four symbol periods, T_s . The \mathcal{G}_{44} decoding algorithm in Equation (30) can be performed to decode the \mathcal{G}_{34} by removing all components in the fourth column of \mathcal{G}_{44} . The combiner collects the received signals from all receive antennas and results the following estimated value of the transmitted symbols:

$$\begin{aligned}
 \tilde{s}_{3k} &= \sum_{j=1}^{N_R} \left\{ \begin{array}{l} H_{1,j,4k}^* r_{1,j,k} + H_{2,j,4k} r_{2,j,k}^* + \frac{1}{2} H_{3,j,4k} (r_{4,j,k} - r_{3,j,k}) \\ -\frac{1}{2} H_{3,j,4k} (r_{3,j,k} + r_{4,j,k})^* \end{array} \right\} \\
 \tilde{s}_{3k+1} &= \sum_{j=1}^{N_R} \left\{ \begin{array}{l} H_{2,j,4k}^* r_{1,j,k} - H_{1,j,4k} r_{2,j,k}^* + \frac{1}{2} H_{3,j,4k} (r_{3,j,k} + r_{4,j,k}) \\ +\frac{1}{2} H_{3,j,4k} (-r_{3,j,k} + r_{4,j,k})^* \end{array} \right\} \\
 \tilde{s}_{3k+2} &= \frac{1}{2} \sqrt{2} \sum_{j=1}^{N_R} \left\{ \begin{array}{l} H_{3,j,4k}^* (r_{1,j,k} + r_{2,j,k}) + (H_{1,j,4k} + H_{2,j,6k}) r_{3,j,k}^* \\ + (H_{1,j,6k} - H_{2,j,4k}) r_{4,j,k}^* \end{array} \right\}
 \end{aligned} \quad (33)$$

The simplified equation of decoding algorithm in Equations (30) and (33) is presented in Appendix 1.

3.0 PERFORMANCE ANALYSIS

The BCH encoder receives K information symbols and results the N coded symbols stated as $\mathcal{C}(N, K)$. Note that, the length of the coded symbol must be the same with the length of OFDM frame. The union bound for the bit error rate of a linear block code $\mathcal{C}(N, K)$ is [11]:

$$P_b \leq \sum_{k=0}^K \sum_{d=0}^N \frac{k}{K} A_{k,d} P_u(d) \quad (34)$$

where $A_{k,d}$ is the number of codewords with input weight k and output weight d , $P_u(d)$ is the unconditional pairwise error performance (PEP), which is defined as the probability of decoding in favour of a codeword with weight d when the all-zero codeword is transmitted. The weight distribution $A_{k,d}$ is obtained directly from the weight enumerator of the code [11].

We denote the number of fading blocks with \mathcal{F} , length of fading block with $m = N/\mathcal{F}$ where N is the length of the coded symbols. For the block fading channels, $P_u(d)$ is a function of the distribution of the d nonzero bits of the codeword among the \mathcal{F}

fading blocks. Assume the number of fading blocks with weight v is f_v and $k = \min(m, d)$. The pattern $\mathbf{f} = \{f_v\}_{v=0}^k$ occurs if f_v 's sum up to \mathcal{F} , and cumulative weight equals d . Having all the possible patterns, the average of the PEP over the patterns is [12]:

$$E_{\mathbf{f}|d}[P_u(d)] = \sum_{f_1=1}^{\mathcal{F}} \sum_{f_2=1}^{\mathcal{F}/2} \cdots \sum_{f_k=1}^{\mathcal{F}/k} P_c(d|\mathbf{f}) p(\mathbf{f}) \quad (35)$$

where $p(\mathbf{f})$ is the weight of occurrence of the pattern \mathbf{f} .

In the following explanation, we introduce the PEP under equivalent block fading in case of independent antennas. We assume M -ary PSK modulation for the given PEP's.

For a given channel code \mathcal{C} , assuming all-zero codeword is transmitted, the PEP of a codeword with weight d given the pattern \mathbf{f} of the fading blocks, is [12]:

$$P_c(d|\mathbf{f}) = Q\left(\sqrt{M \sum_{v=1}^k v \sum_{i=1}^{f_v} \gamma_{v,i}}\right) \quad (36)$$

where $\gamma_{v,i} = h_{v,i}^4 R_c E_b / N_o$ is the signal to noise ratio (SNR) per information bit of the symbols in the i -th fading block which has the weight v , with associated fading coefficient $h_{v,i}$ and R_c is the code rate. The term E_b states the energy of information bit and N_o states energy of noise.

In the case of N_T transmit and N_R receive antennas, the resultant SNR per bit is:

$$\gamma = \frac{1}{N_T} \sum_{i=1}^{N_T} \sum_{j=1}^{N_R} \gamma_{i,j} \quad (37)$$

Recall the Q -function in alternative form in [13] which can be rewritten as:

$$Q(x) = \frac{1}{\pi} \int_0^{\pi-\psi} \exp\left(-\frac{x^2}{2 \sin^2 \theta}\right) d\theta \quad (38)$$

where $\psi = \pi/M$. Thus, PEP conditioned on the block fading pattern \mathbf{f} is [12]:

$$P_c(d|\mathbf{f}) = \frac{1}{\pi} \int_0^{\pi(M-1)/M} \exp\left(-\frac{1}{\sin^2 \theta} \sum_{v=1}^k v \sum_{i=1}^{f_v} \gamma_{v,i}\right) d\theta \quad (39)$$

Averaging the above PEP over the instantaneous SNR γ , the unconditional PEP is $P_u(d|\mathbf{f}) = E\gamma(P_c(d|\mathbf{f}))$, where $E(\cdot)$ is the expectation operator, and it averages out all

the fading coefficients affecting a codeword. Since $\gamma_{v,i}$'s are all independent, the multiple integral reduces to product of integrals,

$$P_c(d|\mathbf{f}) = \frac{1}{\pi} \int_0^{\pi(M-1)/M} \prod_{v=1}^k \prod_{i=1}^{f_v} \int_0^{\infty} \exp\left(-\frac{v\gamma_{v,i}}{\sin^2 \theta}\right) p_\gamma(\gamma_{v,i}) d\gamma_{v,i} d\theta \quad (40)$$

Note that the inner integral is characteristic function of γ , $\Phi(s) = E(e^{s\gamma})$, evaluated at $s = -v/\sin^2 \theta$, hence

$$P_c(d|\mathbf{f}) = \frac{1}{\pi} \int_0^{\pi(M-1)/M} \prod_{v=1}^k \left[\Phi\left(-\frac{v}{\sin^2 \theta}\right) \right]^{f_v} d\theta \quad (41)$$

In the case of independent $\gamma_{i,j}$'s in (37), the resultant SNR is the sum of $N_T N_R$ independent exponential variables and hence has a chi-square distribution with the probability of density function (*pdf*) is [12]:

$$p_\gamma(\gamma) = \frac{1}{(D-1)! \bar{\gamma}^D} \gamma^{D-1} \exp(\gamma/\bar{\gamma}) \quad (42)$$

where

$$\bar{\gamma} = \frac{1}{M_T} \frac{E_b}{N_o} \quad (43)$$

is the average of SNR per bit and $D = N_T N_R$. The characteristic function of its *pdf* is given by:

$$\Phi_\gamma(s) = (1 - s\bar{\gamma})^{-D} \quad (44)$$

Using characteristic function in Equation (34), we obtain the following unconditioned PEP [12]:

$$\begin{aligned} P_u(d|\mathbf{f}) &= \frac{1}{\pi} \int_0^{\pi(M-1)/M} \prod_{v=1}^k \left(1 + \frac{v\gamma}{\sin^2 \theta}\right)^{-f_v D} d\theta \\ &\leq \frac{1}{(M-1)/M} \prod_{v=1}^k (1 + v\bar{\gamma})^{-f_v D} \end{aligned} \quad (45)$$

where the last inequality is the Chernoff bound. One may also obtain the result for quasi-static Rayleigh fading by setting $\mathcal{F} = 1$ which is equivalent to $v = d, f_v = 1$.

4.0 SIMULATION RESULTS

We generate equiprobable-binary data randomly and encode using BCH code with a block length of information $K = 191$ and length of code $N = 255$. This code provides almost $\frac{3}{4}$ of rate and capable to recover 8 bits error. The appropriate size of the matrix interleaved that we chose is 17×15 and size of the matrix de-interleaved is 15×17 . After the bit to symbol conversion, a Gray mapping and PSK constellation mapping were performed consecutively prior to serial-to-parallel conversion. STBC-OFDM maps the parallel symbols to space-time codes and feeds it to OFDM modulators. We use IFFT with $N = 128$ and then add it with cyclic prefix as guard time with the length of 32 (25% of IFFT length). These OFDM blocks are transmitted simultaneously through transmit antennas with equal power.

First, we investigate the performance of our proposed system by using Alamouti's scheme [5] that provides full rate of transmission combined with OFDM and compare the results with maximum-ratio receiver combining (MRRC) technique and also with conventional STBC-OFDM (CSTBC-OFDM). The results are shown in Figure 2. When compared to the single transmit antenna system, our proposed scheme has shown significant probability of error, P_e , improvement. At SNR = 14 dB, the proposed system gives probability of bit error $P_e = 1.5 \times 10^{-2}$ and CSTBC-OFDM experiences probability of bit error $P_e = 3.14 \times 10^{-2}$. At the same value of probability of bit error

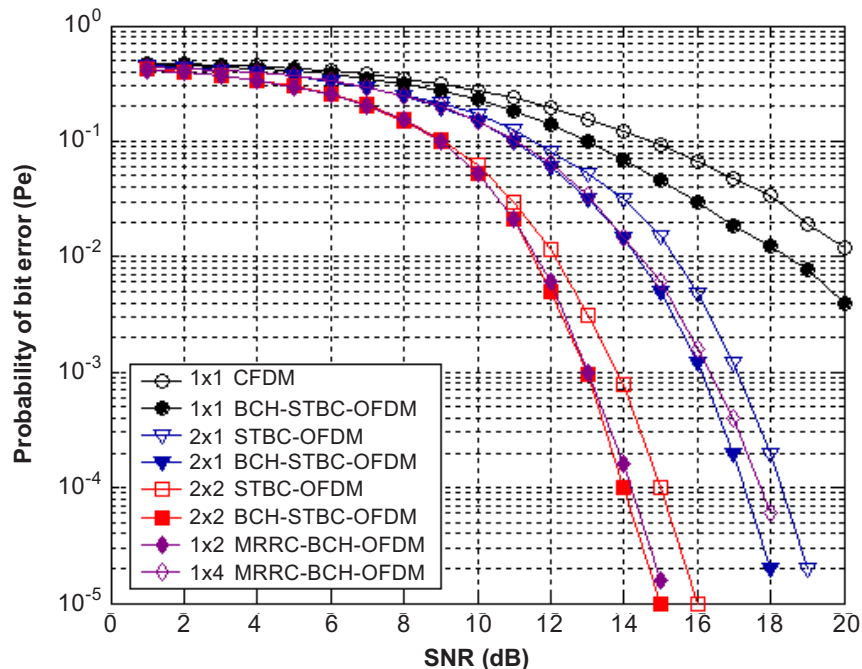

Figure 2 Probability of error performance of the proposed system using \mathcal{G}_{22} compared to MRRC schemes and conventional STBC-OFDM

$P_e = 10^{-4}$, our proposed system has 1 dB advantage in SNR over CSTBC-OFDM. The same results were obtained when the system employed two receive antennas. At SNR = 14 dB, the proposed system reach probability of bit error $P_e = 10^{-4}$ while CSTBC-OFDM reach probability of bit error $P_e = 8 \times 10^{-4}$. At probability of bit error $P_e = 10^{-5}$, the proposed system gives about 1 dB gain over CSTBC-OFDM. Figure 2 also shows that our proposed system performance as good as MRRC technique when employing the same number of antennas.

Figure 3 provide simulation results for transmission of 1 bit/sec/Hz using one (uncoded), two, three and four transmit antennas. The transmission using two transmit antennas employs the binary PSK (BPSK) constellation and the code \mathcal{G}_{22} . For three and four transmit antennas, the QPSK constellation and the codes \mathcal{G}_{38} and \mathcal{G}_{48} , respectively, are used. Since \mathcal{G}_{38} and \mathcal{G}_{48} are half rate codes, again the total transmission rate in each case is 1 bit/sec/Hz. It is shown that at the probability of bit error $P_e = 10^{-4}$, the half rate QPSK \mathcal{G}_{48} gives about 3 dB gain over the half rate QPSK \mathcal{G}_{38} and gives about 6 dB gain over the full rate BPSK \mathcal{G}_{22} code.

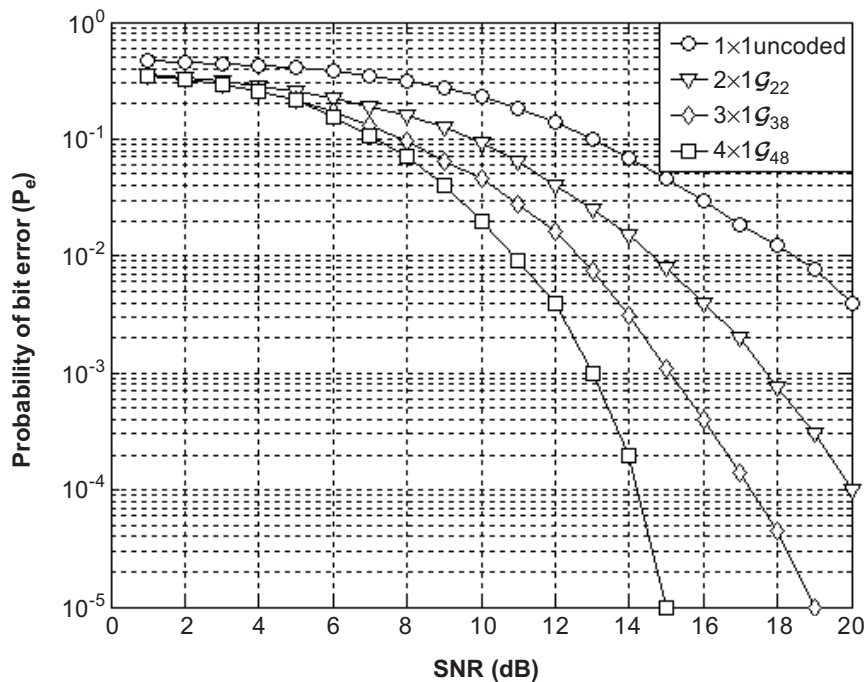

Figure 3 Probability of bit error versus SNR for BCH/STBC-OD/FDM systems at 1 bit/sec/Hz, one receive antenna

In Figure 4, we provide bit rate for transmission of 1.5 bits/sec/Hz employing three and four transmit antennas and the STBC-OD of \mathcal{G}_{34} and \mathcal{G}_{44} , respectively. Both are using the QPSK constellation. Since \mathcal{G}_{34} and \mathcal{G}_{44} have the transmission rate of $\frac{3}{4}$ symbols/sec/Hz, the total transmission rate in each case is 1.5 bits/sec/Hz. From Figure

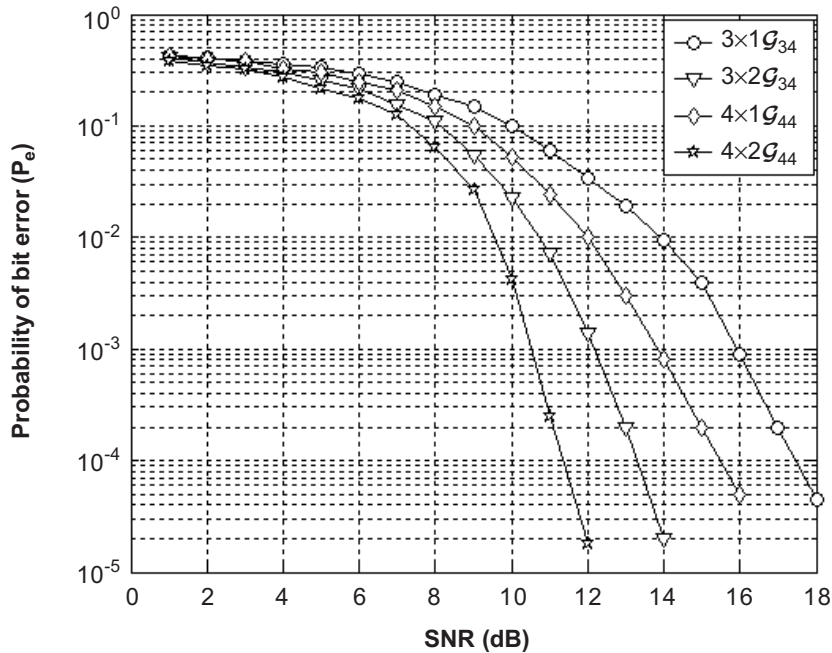

Figure 4 Probability of bit error versus SNR for BCH/STBC-OD/OFDM systems at 1.5 bit/sec/Hz using one and two receive antennas

4, it is seen that at the probability of bit error $P_e = 10^{-4}$ the $\frac{3}{4}$ rate QPSK and \mathcal{G}_{44} gives about 2 dB gain over the use of QPSK and \mathcal{G}_{34} using single receive antenna. The same gain value is also obtained when using two receive antennas.

The above simulations demonstrate that concatenated BCH with STBC-OD in OFDM system can achieve significant gains by increasing the number of transmit antennas.

5.0 CONCLUSION AND FUTURE RESEARCH

We have proposed serially concatenated BCH code with STBC-OD in OFDM systems employing multiple transmit and receive antennas. Our proposed system gives significant gain over CSTBC-OFDM systems both by using multiple transmit antennas or multiple receive antennas. The proposed system gives the same performance as MRRC technique using equal number of antennas. Significant gain was also provided when increasing the number of transmit antennas chains with very little decoding complexity. The simulations results demonstrate that significant gain can be achieved by increasing the number of receive antennas. In the fast-vary channel, any channel estimator schemes cannot estimate the channel state information accurately. Further research is required to investigate the effect of the imperfect channel estimation to the system performance. In future, we will consider the use the unitary space-time coding

and differential space-time block coding that do not require channel state information in the decoding processes. Product turbo code with block codes as its element codes is another alternative code to be investigated in STBC-OD OFDM transmission systems.

REFERENCES

- [1] Stirling-Gallacher, R. A., and Z. Wang. 2001. Improving Performance of Coherent Coded OFDM Systems Using Space-Time Transmit Diversity. *IEEE Electronic Letters*. 37(7): 457-458.
- [2] Li, Y. (Geoffrey), J. C. Chuang, and N. R. Sollenberger. 1999. Transmitter Diversity for OFDM Systems and its Impact on High-Rate Data Wireless Networks. *IEEE Journal on Selected Areas in Communications*. 17(7): 1233-1243.
- [3] Gesbert, D., M. Shafi, S. Da-shan, P. J. Smith, and A. Naguib. 2003. From Theory to Practice: An Overview of MIMO Space-Time Coded Wireless Systems. *IEEE Journal on Selected Areas in Communications*. 21(3): 281-302.
- [4] Tarokh, V., N. Seshadri, and A. R. Calderbank. 1998. Space-Time Codes for High Data Rate Wireless Communications: Performance Criterion and Code Construction. *IEEE Transactions on Information Theory*. 44(2): 744-765.
- [5] Alamouti, S. M. 1998. A Simple Transmit Diversity Technique for Wireless Communication. *IEEE Journal on Selected Areas in Communications*. 16(8): 1451-1458.
- [6] Tarokh, V., H. Jafarkhani, and A. R. Calderbank. 1999. Space-Time Block Codes from Orthogonal Designs. *IEEE Trans. on Information Theory*. 45(5): 1456-1467.
- [7] Tarokh, V., H. Jafarkhani, and A. R. Calderbank. 1999. Space-Time Block Coding for Wireless Communications: Performance Results. *IEEE Journal on Selected Areas in Communications*. 17(3): 451-459.
- [8] Naguib, A. F., V. Tarokh, N. Seshadri, and A. R. Calderbank. 1998. A Space-Time Coding Modem for High-Data-Rate Wireless Communications. *IEEE Journal on Selected Areas in Communications*. 16(8): 1459-1478.
- [9] 3rd Generation Partnership Project 3G TS25.212. 1999. Multiplexing and Channel Coding (FDD). *3GPP Technical Specification Group Radio Access Network*. Released 1999. version 3.5.0 (2000-12).
- [10] Proakis, J. G. 2000. *Digital Communications*, New York: McGraw-Hill. 14: 878-885.
- [11] Benedetto, S., D. Divsalar, G. Montorsi, and F. Pollara. 1998. Serial Concatenation of Interleaved Codes: Performance Analysis, Design, and Iterative Decoding. *IEEE Transactions on Information Theory*. 44(3): 909-926.
- [12] Simon, M. K., and D. Divsalar. 1998. Some New Twists to Problems Involving the Gaussian Probability Integral. *IEEE Transactions on Communications*. 46(2): 200-210.
- [13] Zummo, S.A., and W. E. Stark. 2002. Performance Analysis of Coded Systems over Block Fading Channels. Proceeding on IEEE Vehicular Technology Conference 2002. 1129 - 1133.

APPENDIX

In this appendix, we provide the simplified ML decoding algorithm in Equations (12), (17), (20), (24) and (27).

By substituting Equations (11) and (13) into Equation (12), the decoding algorithm of Equation (12) would be:

$$\begin{aligned}\tilde{s}_{2k} &= \sum_{j=1}^{N_R} \left\{ \left(|H_{1,j,2k}|^2 + |H_{2,j,2k}|^2 \right) s_k + H_{1,j,2k}^* W_{j,2k} + H_{2,j,2k}^* W_{j,2k+1} \right\} \\ \tilde{s}_{2k+1} &= \sum_{j=1}^{N_R} \left\{ \left(|H_{1,j,2k}|^2 + |H_{2,j,2k}|^2 \right) s_{2k+1} + H_{2,j,2k}^* W_{1,j,2k} - H_{1,j,2k}^* W_{j,2k+1} \right\}\end{aligned}\quad (46)$$

Substituting Equations (16) and (18) into Equation (17), we obtain the simplified form of Equation (17):

$$\begin{aligned}\tilde{s}_{4k} &= \sum_{j=1}^{N_R} \left\{ \left(2 \sum_{i=1}^4 |H_{i,j,8k}|^2 \right) s_{4k} + H_{1,j,8k}^* W_{j,8k} + H_{2,j,8k}^* W_{j,8k+1} + H_{3,j,8k}^* W_{j,8k+2} \right. \\ &\quad \left. + H_{4,j,8k}^* W_{j,8k+3} + H_{1,j,8k} W_{j,8k+4}^* + H_{2,j,8k} W_{j,8k+5}^* + H_{3,j,8k} W_{j,8k+6}^* + H_{4,j,8k} W_{j,8k+7}^* \right\} \\ \tilde{s}_{4k+1} &= \sum_{j=1}^{N_R} \left\{ \left(2 \sum_{i=1}^4 |H_{i,j,8k}|^2 \right) s_{4k+1} + H_{2,j,8k}^* W_{j,8k} - H_{1,j,8k}^* W_{j,8k+1} - H_{4,j,8k}^* W_{j,8k+2} \right. \\ &\quad \left. - H_{3,j,8k}^* W_{j,8k+3} + H_{2,j,8k} W_{j,8k+4}^* - H_{1,j,8k} W_{j,8k+5}^* - H_{4,j,8k} W_{j,8k+6}^* - H_{3,j,8k} W_{j,8k+7}^* \right\} \\ \tilde{s}_{4k+2} &= \sum_{j=1}^{N_R} \left\{ \left(2 \sum_{i=1}^4 |H_{i,j,8k}|^2 \right) s_{4k+2} + H_{3,j,8k}^* W_{j,8k} + H_{4,j,8k}^* W_{j,8k+1} - H_{1,j,8k}^* W_{j,8k+2} \right. \\ &\quad \left. - H_{2,j,8k}^* W_{j,8k+3} + H_{3,j,8k} W_{j,8k+4}^* + H_{4,j,8k} W_{j,8k+5}^* - H_{1,j,8k} W_{j,8k+6}^* - H_{2,j,8k} W_{j,8k+7}^* \right\} \\ \tilde{s}_{4k+3} &= \sum_{j=1}^{N_R} \left\{ \left(2 \sum_{i=1}^4 |H_{i,j,8k}|^2 \right) s_{4k+3} + H_{4,j,8k}^* W_{j,8k} - H_{3,j,8k}^* W_{j,8k+1} + H_{2,j,8k}^* W_{j,8k+2} \right. \\ &\quad \left. - H_{1,j,8k}^* W_{j,8k+3} + H_{4,j,8k} W_{j,8k+4}^* - H_{3,j,8k} W_{j,8k+5}^* + H_{2,j,8k} W_{j,8k+6}^* - H_{1,j,8k} W_{j,8k+7}^* \right\}\end{aligned}\quad (47)$$

Using the same way, we obtain the simplified presentation of Equation (20) as:

$$\begin{aligned}
\tilde{s}_{3k} &= \sum_{j=1}^{N_R} \left\{ \left(2 \sum_{i=1}^3 |H_{i,j,8k}|^2 \right) s_{3k} + H_{1,j,8k}^* W_{j,8k} + H_{2,j,8k}^* W_{j,8k+1} \right. \\
&\quad \left. + H_{3,j,8k}^* W_{j,8k+2} + H_{1,j,8k} W_{j,8k+4}^* + H_{2,j,8k} W_{j,8k+5}^* + H_{3,j,8k} W_{j,8k+6}^* \right\} \\
\tilde{s}_{3k+1} &= \sum_{j=1}^{N_R} \left\{ \left(2 \sum_{i=1}^3 |H_{i,j,8k}|^2 \right) s_{3k+1} + H_{2,j,8k}^* W_{j,8k} - H_{1,j,8k}^* W_{j,8k+1} \right. \\
&\quad \left. + H_{3,j,8k}^* W_{j,8k+3} + H_{2,j,8k} W_{j,8k+4}^* - H_{1,j,8k} W_{j,8k+5}^* + H_{3,j,8k} W_{j,8k+7}^* \right\} \\
\tilde{s}_{3k+2} &= \sum_{j=1}^{N_R} \left\{ \left(2 \sum_{i=1}^3 |H_{i,j,8k}|^2 \right) s_{3k+2} + H_{3,j,8k}^* W_{j,8k} - H_{1,j,8k}^* W_{j,8k+2} \right. \\
&\quad \left. - H_{2,j,8k} W_{j,8k+3}^* + H_{3,j,8k} W_{j,8k+4}^* - H_{1,j,8k} W_{j,8k+6}^* - H_{2,j,8k} W_{j,8k+7}^* \right\} \\
\tilde{s}_{3k+3} &= \sum_{j=1}^{N_R} \left\{ \left(2 \sum_{i=1}^3 |H_{i,j,8k}|^2 \right) s_{3k+3} - H_{3,j,8k}^* W_{j,8k} + H_{2,j,8k}^* W_{j,8k+2} \right. \\
&\quad \left. - H_{1,j,8k} W_{j,8k+3}^* - H_{3,j,8k} W_{j,8k+5}^* + H_{2,j,8k} W_{j,8k+6}^* - H_{1,j,8k} W_{j,8k+7}^* \right\}
\end{aligned} \tag{48}$$

Substituting Equations (23) and (25) into Equation (24), we obtain the simplified form of Equation (24):

$$\begin{aligned}
\tilde{s}_{4k} &= \sum_{j=1}^{N_R} \left\{ \left(2 \sum_{i=1}^2 |H_{i,j,4k}|^2 + \frac{1}{2} \sum_{i=3}^4 |H_{i,j,4k}|^2 \right) s_{4k} + H_{1,j,4k}^* W_{j,k} + H_{2,j,4k} W_{j,4k+1}^* \right. \\
&\quad \left. + \frac{1}{2} (H_{3,j,4k}^* - H_{4,j,4k}^*) (W_{j,4k+3} - W_{j,4k+2}) \right. \\
&\quad \left. - \frac{1}{2} (H_{3,j,4k}^* + H_{4,j,4k}^*) (W_{j,4k+2} + W_{j,4k+3}) \right\} \\
\tilde{s}_{4k+1} &= \sum_{j=1}^{N_R} \left\{ \left(2 \sum_{i=1}^2 |H_{1,j,4k}|^2 + \frac{1}{2} \sum_{i=3}^4 |H_{i,j,4k}|^2 \right) s_{4k+1} + H_{2,j,4k}^* W_{j,k} - H_{1,j,4k} W_{j,4k+1}^* \right. \\
&\quad \left. + \frac{1}{2} (H_{3,j,4k}^* - H_{4,j,4k}^*) (W_{j,4k+2} + W_{j,4k+3}) \right. \\
&\quad \left. - \frac{1}{2} (H_{3,j,4k}^* + H_{4,j,4k}^*) (W_{j,4k+3} - W_{j,4k+2}) \right\}
\end{aligned} \tag{49}$$

$$\tilde{s}_{4k+2} = \sqrt{2} \sum_{j=1}^{N_R} \left\{ \begin{aligned} & \left(2 \sum_{i=1}^4 |H_{1,j,4k}|^2 \right) \mathfrak{s}_{4k+2} + \frac{1}{2} H_{3,j,4k}^* (W_{j,4k} + W_{j,4k+1}^*) \\ & + \frac{1}{2} H_{4,j,4k}^* (W_{j,4k} - W_{j,4k+1}) + \frac{1}{2} (H_{1,j,4k} + H_{2,j,4k}) W_{j,4k+2}^* \\ & + \frac{1}{2} (H_{1,j,4k} - H_{2,j,4k}) W_{j,4k+3}^* \end{aligned} \right\}$$

The similar result was obtained for Equation (27) simplification as:

$$\begin{aligned} \tilde{s}_{3k} &= \sum_{j=1}^{N_R} \left\{ \begin{aligned} & \left(\sum_{i=1}^2 |H_{i,j,4k}|^2 + \frac{1}{2} |H_{3,j,4k}|^2 \right) \mathfrak{s}_{3k} + H_{1,j,4k}^* W_{j,k} + H_{2,j,4k} W_{j,4k+1}^* \\ & + \frac{1}{2} H_{3,j,4k}^* (W_{j,4k+3} - W_{j,4k+2}) - \frac{1}{2} H_{3,j,4k} (W_{j,4k+2} + W_{j,4k+3}) \end{aligned} \right\} \\ \tilde{s}_{3k+1} &= \sum_{j=1}^{N_R} \left\{ \begin{aligned} & \left(\sum_{i=1}^2 |H_{i,j,4k}|^2 + \frac{1}{2} |H_{3,j,4k}|^2 \right) \mathfrak{s}_{3k+1} + H_{2,j,4k} W_{j,4k} - H_{1,j,4k} W_{j,4k+1}^* \\ & + \frac{1}{2} H_{3,j,4k}^* (W_{j,4k+2} + W_{j,4k+3}) + \frac{1}{2} H_{3,j,4k} (-W_{j,4k+2} + W_{j,4k+3}) \end{aligned} \right\} \quad (50) \\ \tilde{s}_{3k+2} &= \frac{1}{2} \sqrt{2} \sum_{j=1}^{N_R} \left\{ \begin{aligned} & \left(\sum_{i=1}^2 |H_{i,j,4k}|^2 + 2 |H_{3,j,4k}|^2 \right) \mathfrak{s}_{3k+2} + H_{3,j,4k}^* (W_{j,4k} + W_{j,4k+1}^*) \\ & + (H_{1,j,4k} + H_{2,j,4k}) W_{j,4k+2}^* (H_{1,j,4k} - H_{2,j,4k}) W_{j,4k+3}^* \end{aligned} \right\} \end{aligned}$$