

FLUID BEHAVIOR INVESTIGATION ON A SINGLE-PHASE EJECTOR USING NUMERICAL APPROACH

Mohamad Nur Hidayat Mat* and Muhammad Nurashman Ahmad Noordin

School of Mechanical Engineering, Faculty of Engineering
Universiti Teknologi Malaysia
81310 UTM Johor Bahru, Johor, Malaysia

*Corresponding email: mn.hidayat@utm.my

Article history

Received
19th May 2022
Revised
16th January 2023
Accepted
16th January 2023
Published
17th January 2023

ABSTRACT

This study aims to investigate fluid flow behaviors inside an ejector for a single-phase system. Numerical simulation has been employed to investigate the characteristics of the ejector. The numerical process begins with model creation, mesh sensitivity study for optimal mesh size, and validation study. Seven geometrical parts of the ejector were modified which were nozzle diameter, venturi tube neck diameter, nozzle distance, venturi tube neck length, straight pipe length, mixing chamber diameter, and mixing chamber length. Through these seven aspects, a total of 82 design points has been generated by the design of the experiment algorithm and the best candidates design that provide optimum performance are 2.12mm, 18.93mm, 3.12mm, 80.71mm, 195.9mm, 138.63mm, and 165.64mm respectively. These parameters contributed 0.0462% more efficiency than the existing design.

Keywords: *Optimization, parametric study, ejector, numerical*

© 2022 Penerbit UTM Press. All rights reserved

1.0 INTRODUCTION

An ejector is a simple piece of equipment or device that transmits liquid or gas by using a high-pressure motive medium whether liquid or gas to allow low-pressure suction of fluid, mixing to an intermediate discharge pressure [1]. The ejector has various name called in the industry and it is called by names including the eductor, jet pump, jet air pump, vacuum ejector, and jet ejector pump. However, they all work the same, but only the medium flow inside is different from others with a variety of inlet liquid-liquid, gas-liquid, or gas-gas. The working principle of an ejector is that high-pressure motive fluid (liquid or gaseous) is flow in a narrow pipe with the converging nozzle as shown in Figure 1. The fluid suddenly expands in the venturi tube which creates Bernoulli's effect of vacuum inside of the large pipe and sucks fluid from the suction inlet. The velocity of the fluid increase as it flows in the venturi tube. The pressure at the outlet is intermediate because of the low pressure from the suction inlet [2].

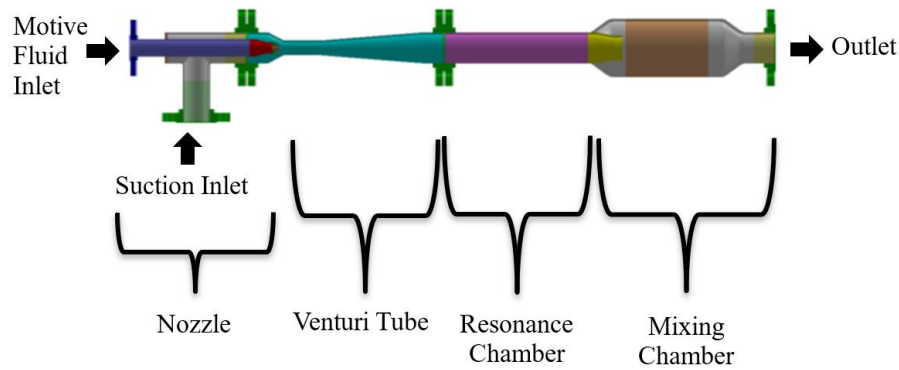

Figure 1: Typical ejector components

Therefore, the design parameter of an ejector plays important role in increasing the outlet pressure while maximizing the volume flow rate from the suction. Since these pumps do not have moving parts, they are widely used due to their simplicity and high reliability. However, there is a problem with the efficiency and performance of the jet pump that needs to be addressed.

Many parameters could improve energy efficiency for an ejector. According to some researchers, the entrainment ratio plays an important role in providing good performance for the ejector [3]. The entrainment ratio is the ratio of the mass flow rate of the secondary fluid to the mass flow rate of the primary fluid. While another ratio which also stated to affect the performance of the ejector is the area ratio. The area ratio is the ratio of the nozzle area and the suction area at the venturi inlet. The performance of the ejector can be achieved by changing the area ratio [4]. Throat length in the ejector is also an important factor to perform better. Because of friction losses in the throat, jet pumps with longer mixing lengths have poorer performance. As a result of the shorter throat length, the mixing is carried on into the diffuser, which results in a performance loss as well [5].

Besides throat length in the venturi tube, convergent and divergent angles are also crucial parameters [6]. With a larger diverging angle, entrainment performance will be reduced under low power settings [7]. A diffuser angle of 5deg is optimal for best efficiency. The nozzle is where the motive fluid enters an ejector whether liquid or in gas form. Therefore, the diameter or radius of the entering hole must be affecting the performance of the ejector [8].

However, despite all these parameters, research communities did not investigate ejectors with this kind of mixing chamber. Therefore, this research will investigate the optimized parameter to have a high efficiency without sacrificing the flow rate. Next, this research also includes an investigation of fluid flow behavior inside an ejector. Finally, to conduct a validation study with previous research.

2.0 METHODOLOGY

2.1 Simulation Model

Computational domains with dimensions as shown in Figure 2, Figure 3, and Figure 4 were created using the CAD tool. The 3D steady flow is used for the numerical simulation of water flow for the ejector. The simulation was performed using Ansys Fluent 2022 Version R1. This numerical simulation aims to study the effect of geometrical parameters on an ejector based on control volume method. The ejector act as a body of equipment while the liquid represents the inner volume of the ejector. The fluid medium enters through the nozzle in the center of the ejector. The pressure for the inlet pressure is 1 bar or 10 kPa as presented in Table 1.

Table 1: Ejector properties

Parameter	Value
Inlet Pressure [Pa]	10000
Suction Initial Pressure [Pa]	0
Outlet Initial Pressure [Pa]	0
Medium	Water (liquid)
Density [kg/m ³]	998.2
Viscosity [kg/m s]	10 ⁻³ Pa. s

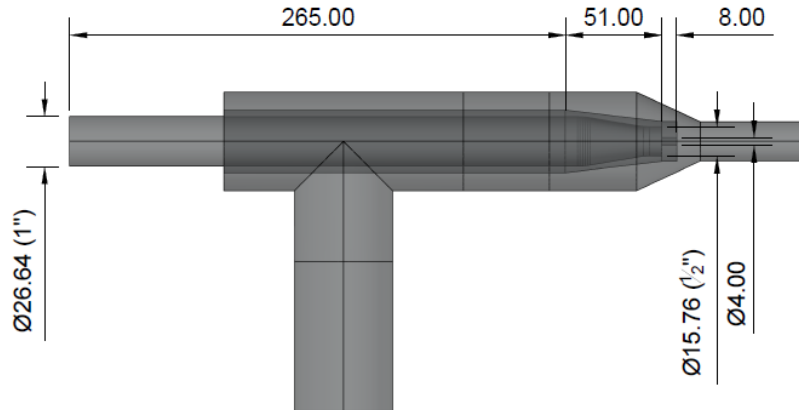

Figure 2: Measurement for jet inlet and suction inlet

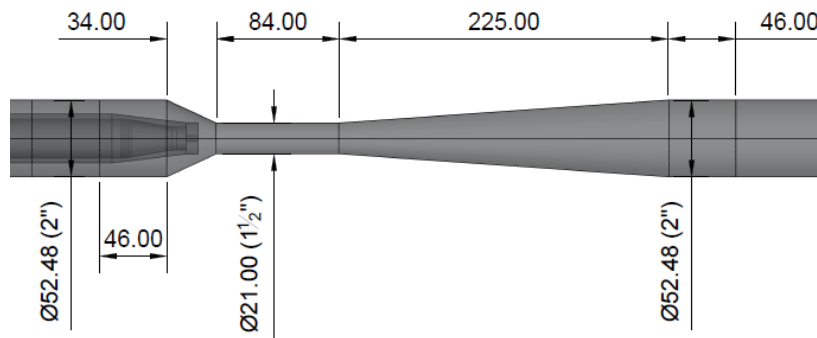

Figure 3: Measurement for venturi tube

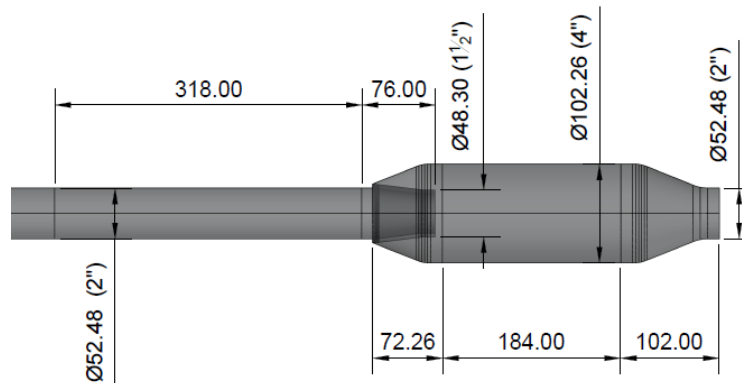

Figure 4: Measurement resonance chamber and mixing chamber

2.2 Mesh Sensitivity Study

The mesh sensitivity study was conducted to compare the result of different types of mesh elements [9]. The three types of meshes are coarse, intermediate, and fine meshes [10]. The size of the mesh is to be input by the researcher while the number of mesh is generated automatically from size [11]. Previous research from Arun et al.[12] is conducted using CFD simulation to do a mesh sensitivity study. The model from Arun et al. has been modeled to ease the study. The study conducted is applied to the 3D model as the model from Arun et. and the results from the research study are conducted with similar criteria. Therefore, the study must be followed exactly with previous research experimental research[12].

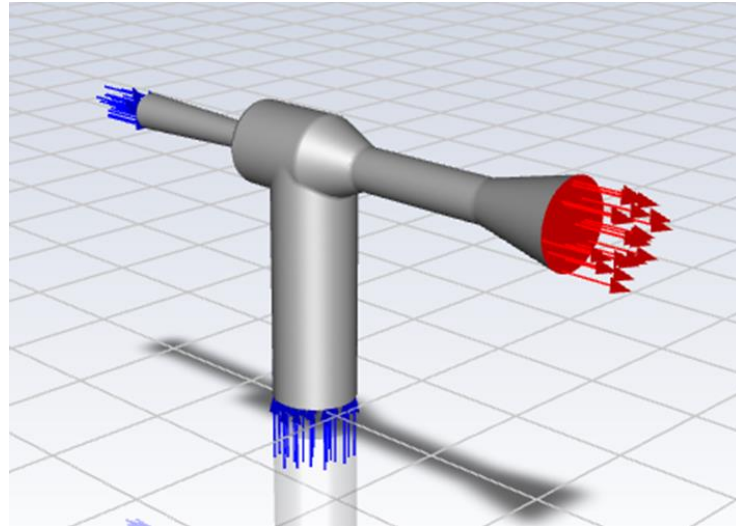

Figure 5: Geometrical modelling of the ejector

Table 2: Relative error and grid convergence index

Model Outputs	
Relative Error (e21)	0.87%
Extrapolated Relative Error (e21 ^{extr})	1.22%
Grid Convergence Index (GCI21)	1.55%

In a nutshell, the fine mesh is accepted as it is lower than 10% of relative error and the extrapolated value is near to the infinitely fine mesh. These data should be used in the research as it has proven to be more accurate and near to accurate experimental results.

2.3 Validation Study

A validation study is conducted compared to the Arun et al. results. The parameter compared is flowrate values from the simulation compared with flowrate from experimental data Arun et al. three data will be compared which are for inlet pressure 0.26 MPa, 0.22 Mpa, and lastly is 0.14 MPa. The relative error gathered from the simulation software is tabulated in Table 3

Table 3: Relative error for flow rate values between Arun et al. [12] and the present

Inlet Pressure (Pa)	Flowrate by Arun et al. (kg/s)	Flowrate (kg/s)	Relative error
264064.64	0.42	0.2933	30.17%
224943.96	0.39	0.2671	31.51%
146702.58	0.32	0.2019	36.9%

3.0 RESULTS AND DISCUSSION

3.1 Velocity

Figure 6 shows the velocity contour for the cross-section of the ejector from the jet inlet to the ejector outlet. In this figure, there is also a detailed view that shows a closer view of the nozzle. The highest velocity is 23ms-1 which is at the ejector nozzle where the water moves from a large cross-section area which is from the jet inlet. After that, it was forced through a very small area that is the nozzle. After that, the velocity drops drastically during coming out from the nozzle due to going through a large area rather than a small nozzle area. The principle related to this is Bernoulli's principle. According to the continuity equation, in the same flow rate, the smaller cross-section will face higher velocity. This can be seen when pinching the water hose pipe to spray water to long distance point.

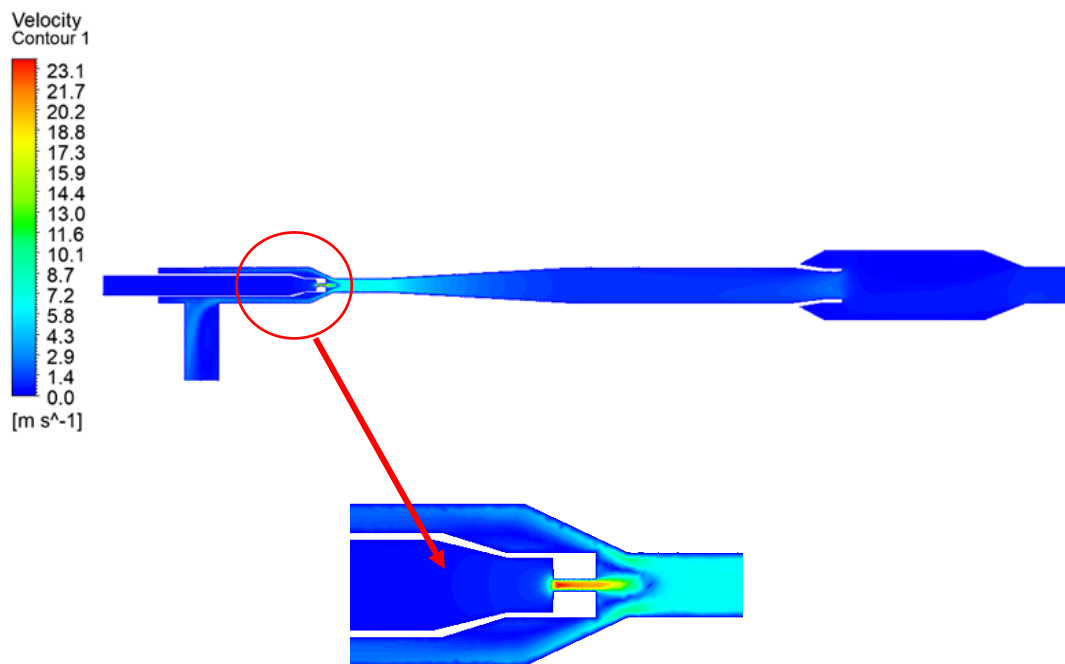

Figure 6: Contour for the velocity at the outlet

3.2 Pressure

As in figure 7, the red contour shows a high pressure of 262.87kPa because the jet inlet set in the simulation is 274.57kPa which can be seen decreasing by 12kPa through the simulation result. After the nozzle, the water that passes through the venturi tube has decreased its pressure to a pressure range of 30kPa and below, which is light blue. After passing through the divergent venturi tube, the pressure rises to the range of 50kPa, which is closer to green and the higher the pressure. This visible principle is the same for the velocity contour which is Bernoulli's principle in the conservation of mass. During the converge, the water that passes through a small area will cause the velocity to increase while the pressure will decrease. After diverging towards a large cross-section, the velocity decreases resulting in increased pressure. After converging towards a large cross-section, the velocity decreases resulting in increased pressure.

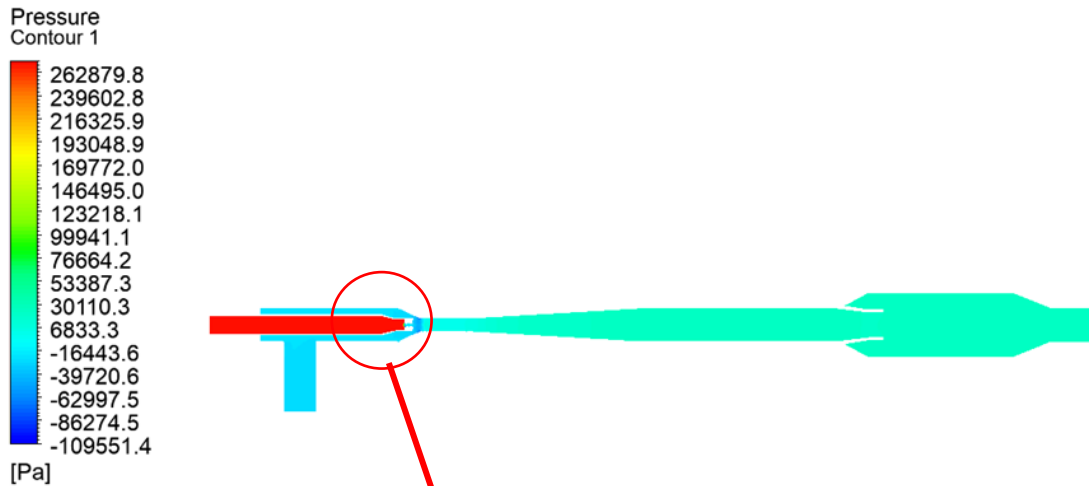

Figure 7: Contour for pressure at the outlet

3.3 Velocity Vectors

The velocity vector on the ejector body represents the rate of change of the position in the ejector. The value or representation in the velocity vector contour is the same as the velocity vector. But in the velocity vector, the amount of particle movement can be seen clearly in this contour. The contour for the velocity vector is shown in Figure 8.

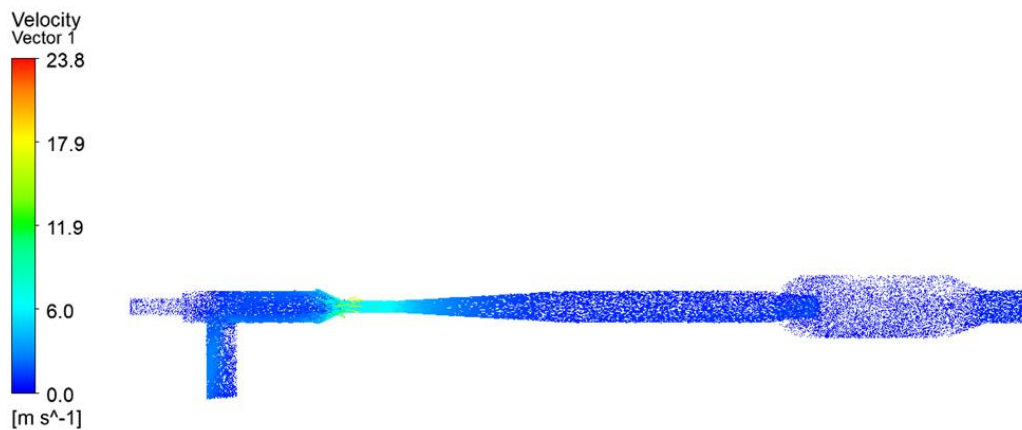

Figure 8: Contour for velocity vector on ejector body

3.4 Flow Properties Inside of An Ejector

Figure 9 shows the jet inlet velocity against the outlet ejector's velocity measured in m/s ranging from 100 to 500 kPa with an increment of 100 kPa. The result indicates that jet inlet velocity increases linearly with increasing outlet velocity. The maximum and minimum values of outlet velocity are 0.6 and 0.2 respectively.

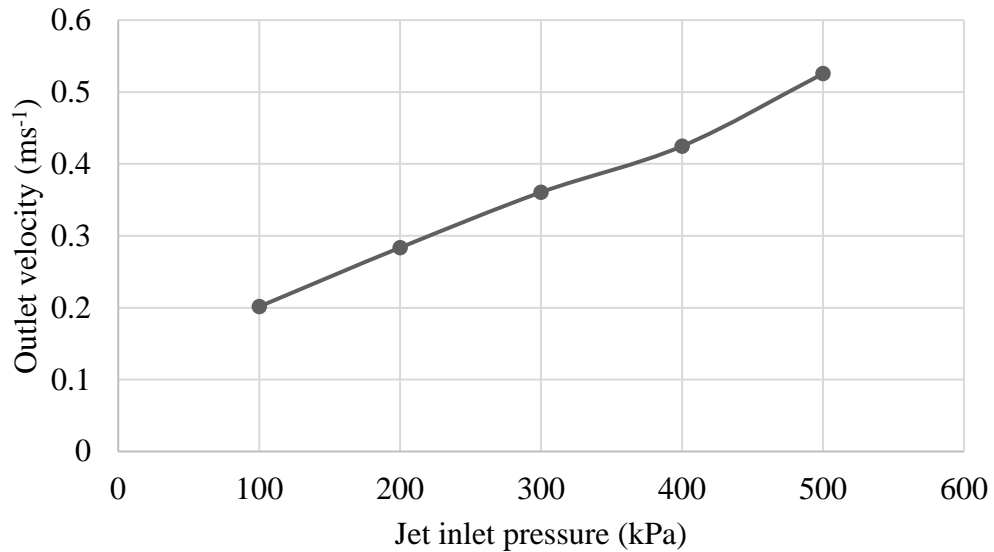

Figure 9: Jet Inlet Pressure Vs Outlet Mass Flow Rate

4.0 CONCLUSION

All optimized parameters conducted play an important role in contributing to excellent efficiency and good performance. The seven parameters taken for the optimization study consist of 82 design points. The optimized parameters from this study capable to improve the efficiency for up to 0.0462 %. This is due to the ejector model have reach optimum size.

ACKNOWLEDGMENTS

The author would like to acknowledge UTM for helpings students in completing this research study. My sincere appreciation also extends to all my colleagues and others who have aided me on various occasions. Their views and tips are useful indeed. Unfortunately, it is not possible to list all of them in this limited space. I am grateful to all my family members.

REFERENCES

1. Mazzuto, G., et al., *The Digital Twin Realization of an Ejector for Multiphase Flows*. Energies, 2021. **14**(17): p. 5533.
2. Ahmed, Z., *Quantitative flow measurement and visualization of cavitation initiation and cavitating flows in a converging-diverging nozzle*. 2017, Kansas State University.
3. Tang, Y., et al., *Performance improvement of steam ejectors under designed parameters with auxiliary entrainment and structure optimization for high energy efficiency*. Energy Conversion and Management, 2017. **153**: p. 12-21.
4. Yang, Y., et al., *Effect of area ratio of the primary nozzle on steam ejector performance considering nonequilibrium condensations*. Energy, 2021. **237**: p. 121483.
5. Aidoun, Z., et al., *Current advances in ejector modeling, experimentation and applications for refrigeration and heat pumps. Part I: single-phase ejectors*. Inventions, 2019. **4**(1): p. 15.
6. Li, M., et al., *Study of Venturi tube geometry on the hydrodynamic cavitation for the generation of microbubbles*. Minerals Engineering, 2019. **132**: p. 268-274.
7. Feng, J., et al., *Performance analysis and parametric studies on the primary nozzle of ejectors in proton exchange membrane fuel cell systems*. Energy Sources, Part A: Recovery, Utilization, and Environmental Effects, 2020: p. 1-20.
8. Bradshaw, P., *Experimental Fluid Mechanics: Thermodynamics and Fluid Mechanics Division*. 2016: Elsevier.
9. Zabolotnii, E., N.R. Morgenstern, and G.W. Wilson, *Mesh sensitivity in numerical models of strain-weakening systems*. Computers and Geotechnics, 2021. **136**: p. 104253.
10. Feather, W.G., H. Lim, and M. Knezevic, *A numerical study into element type and mesh resolution for crystal plasticity finite element modeling of explicit grain structures*. Computational Mechanics, 2021. **67**(1): p. 33-55.
11. Schneider, K., B. Klusemann, and S. Bargmann, *Automatic three-dimensional geometry and mesh generation of periodic representative volume elements for matrix-inclusion composites*. Advances in Engineering Software, 2016. **99**: p. 177-188.
12. Arun, K., S. Tiwari, and A. Mani, *Three-dimensional numerical investigations on rectangular cross-section ejector*. International Journal of Thermal Sciences, 2017. **122**: p. 257-265.