



Journal of Advanced Research in Applied Mechanics

Journal homepage:
https://semarakilmu.com.my/journals/index.php/appl_mech/index
ISSN: 2289-7895



IoT-Based Instrumented Bicycle Handlebar for Children with Autism Spectrum Disorder

Muhammad Afendi Mohaini¹, Nur Safwati Mohd Nor^{1,*}, Maziah Mohamad¹, Nurzal Effiyana Ghazali², Hendri Maja Saputra³

¹ School of Mechanical Engineering, Faculty of Engineering, Universiti Teknologi Malaysia, 81310 Skudai, Johor, Malaysia

² School of Electrical Engineering, Faculty of Engineering, Universiti Teknologi Malaysia, 81310 Skudai, Johor, Malaysia

³ Research Center for Smart Mechatronics, National Research and Innovation Agency (BRIN), Kampus BRIN, KST Samaun Samadikun, Jl. Sangkuriang, Dago, Kec. Coblong, Bandung 40135, Indonesia

ARTICLE INFO

Article history:

Received 11 January 2023

Received in revised form 15 March 2023

Accepted 20 March 2023

Available online 9 April 2023

Keywords:

Autism Spectrum Disorder; monitoring system; handlebar; Internet of Things

ABSTRACT

Common symptoms detected by children with autism spectrum disorder (ASD) include having problems with their fine and gross motor skills. One of the parameters usually associated with the development of ASD children's motor skill performance is Handgrip Strength (HGS). In healthcare, data gathering for the purpose of rehabilitation and therapy are usually conducted manually by the trainer or therapist for multiple candidates in a continuous intervention plan over days, weeks, or even months. This traditional and restrictive approach might not result in prompt, effective, and accessible health services or care that is centred on the needs of the patient. This creates a gap in the adoption of digital transformation-based solutions, particularly in giving the benefit of having a therapist, trainer, or guardian who can track the progress of treatment interventions online via a web application. Hence, this study aims to develop a bicycle handlebar with monitoring systems technology such as an IoT module, hand grip sensor, and heart rate to be used as an intervention tool for ASD children during the physical therapy session. The bicycle handlebar is customized and designed in SolidWorks software. It is 3D Printed to integrate the usage of sensors such as load cells and heart rate sensors to track the motor skill condition of ASD children. The handlebar is designed at a diameter of approximately 30 mm to enable an optimum reading of children's handgrip strength. The data logging system uses the TTGO T-Display with ESP32 microcontroller to allow a wireless and seamless data reading and transfer. Data from the sensors are sent via Wi-Fi to a custom website, Smart Fi-cycle IoT Website, allowing users to access through devices such as mobile phones and PC/Laptop. This system will enable patients and interventionists to track their motor skill performance through a systematic monitoring system.

1. Introduction

Nowadays, the human lifestyle has moved or changed from the conventional environment to a new era of digital technologies, which offer new opportunities for identifying needs and delivering

* Corresponding author.

E-mail address: nursafwati@utm.my

<https://doi.org/10.37934/aram.105.1.1227>

healthcare, such as prevention and health promotion to curative interventions and self-management [1]. For example, the digital transformation in the application of rehabilitation, therapy, and clinical intervention is significant in producing a transition from an industrial society to an information society through sensors and communication technologies. Rehabilitation and therapy in healthcare are commonly using manual data collection recorded by the trainer or therapist for more than one candidate in a continuous intervention plan by days, weeks, or even months. This conventional and rigid method may not be able to achieve a timely, efficient, and equitable health services and people-centeredness of care.

Autism spectrum disorder (ASD) is a disease developing in a spectrum of behavioural symptoms ranging from moderate to severe [2]. The symptoms of Autism are usually detected at an early of two or three years. Some of the early signs or symptoms that can be found in ASD children are academic problems and speech delay. Children with autism spectrum disorder (ASD) are also usually having issues and difficulties in coordination, posture control, handgrip strength, and especially in communication and social interaction [3-4].

Local statistical data are still lacking in an epidemiological study that covers the statistical data on ASD prevalence in Malaysia. The occurrence probability of ASD in Malaysia is, however, obtained through an alternative study that applies Modified Checklist for Autism in Toddlers (M-CHAT) to children ages between 18 to 35 months, showing that there is approximately 1.6 patient in every 1,000 persons as compared to the USA which is 14.7 per 1,000 [5].

As the number is expected to increase as the year progresses, a remedy and rehabilitation program should be further explored and advanced to ensure those diagnosed with ASD can still live normally. One of the methods for intervention with autistic children is using a balance bike. Research conducted by [6] suggested interventionists implement the use of a balance bike in a physical therapy activity or exercise as it can benefit in building motor skills, improve strength, posture and balance.

In order to provide a more effective remedy for improving ASD children's motor skill performance, a method to introduce and integrating mechanical approach through the instrumented bike into the intervention session seems plausible to be carried out. Instrumented bicycle is defined as a tool used to understand the cyclist's behavior and cycling condition by implementing various types of sensors [7]. The development of new product should implement the usage of modern technologies as it is beneficial to many people [8]. The importance of implementing instrumented bike in the bike learning environment is that the motor skill performance and children's learning progress can be monitored directly and analyzed by the therapist. An automatic sensor-based monitoring system which can provide analytical data for internal validity to predict and analyze the motor skill is still absence in this field and require improvement [9-11]. It also enables the therapist to plan early or extra remedies for the children where they find necessary.

Meanwhile, a monitoring system is significant in collecting and analyzing data from sensors, thus allowing the health trainers and therapists to track the intervention progress and performance anytime and anywhere easily. Therefore, this research aims to develop a smart IoT-based bike riding therapy for children that can monitor important parameters for motor skill performance, specifically the handgrip strength and heart rate during bike riding intervention. This system consists of hardware (collecting, converting, and sending data from sensors) and software components (data communication and web application to display, store and manage the data).

2. Methodology

2.1 Method of Measuring Handgrip Strength

The most common method of measuring handgrip strength is by using Force Sensitive Resistor (FSR) and Loadcell. The usage of FSR to measure handgrip requires a precise positioning to certain area of the palm to obtain correct data. This method is usually incorporated with the usage of glove to fix the position of the FSR [12]. This method is, however, not suitable to be used in this project due to its incapability to be fixed to the bicycle and requires steady positioning of the hand which is a difficult measure to be used for a child. Hence, an alternative method inspired by Esposito [13], using loadcell which is incorporated in a handlebar is chosen. The size of the load cell is small enough to be incorporated as a part of the handlebar by placing the sensor inside a two-half-cylinder handle.

2.2 Method of Measuring Heart Rate

XD-58C Pulse Sensor is used in this project to measure the heart rate of the children while riding the bicycle. The sensors can be used by fixing the sensor onto either fingertip or earlobe to obtain the sensor reading. The sensor can operate at a supply voltage of 3.3V or 5V. The sensor is optimal to be used in this project as it integrated with an optical amplifier and noise elimination circuit. The normal resting heartbeat reading for a healthy children age ranges from 60 to 190 bpm.

2.3 Optimum Size of Handlebar

Attaining a maximum reading of gripping force while gripping a handlebar can be achieved by using an optimal size handlebar as in Figure 1, in which the fingertips and the thumb tip can react against the palm [14]. So, in order to achieve an optimum handlebar size that could present a maximum gripping force, [15] presented a formula to calculate the handlebar sizes based on the user hand size. The said formula can be seen below.

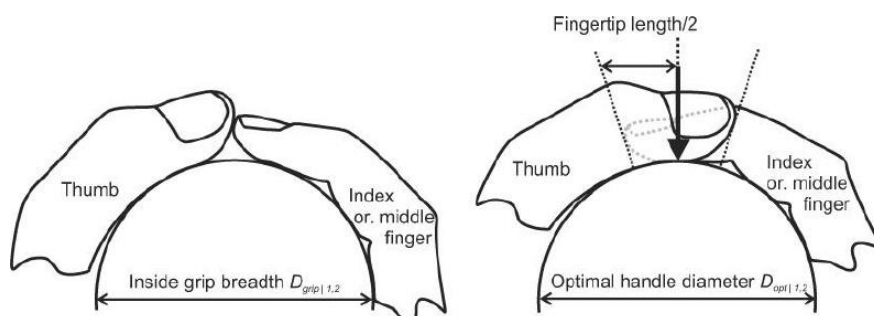

Fig. 1. Drawing of inside grip breadth and optimal handle diameter [16]

$$\text{Optimal handle diameter} = \left(\frac{\text{optimal handle circumference}}{\pi} \right) \quad (1)$$

$$= \frac{\text{inside Grip Breadth} \times \pi - \frac{(\text{middle fingertip length} + \text{thumb top length})}{2}}{\pi} \quad (2)$$

$$= \text{Inside grip breadth} - \frac{0.133 \times \text{hand length}}{\pi} \quad (3)$$

In order to calculate the optimal diameter of the handlebar, the general children's hand anthropometry is obtained from research done by Ran *et al.*, [17] which presents the statistical values

of hand anthropometric dimensions of Asian children aged from 4 to 10 years old. Table 1 and Table 2 illustrate the collected data of boys and girls for 4-6 years old and 7-10 years old respectively.

Table 1

The statistical values of hand anthropometric dimensions (4-6 years old) [17]

Dimensions(mm)	Boys (N=1138)				Girls (N=1140)			
	M	SD	P5	P95	M	SD	P5	P95
Hand length	124.1	9.3	110.1	138.7	122.0	8.4	108.2	136.5
Hand breadth at metacarpals	58.4	4.0	52.3	64.7	56.5	3.7	50.7	62.6
Palm length perpendicular	71.0	5.6	62.7	80.4	69.3	5.2	61.0	78.2
Index finger length	48.2	4.0	42.2	55.1	48.0	3.8	41.6	53.9
Thumb length	39.2	3.7	33.9	45.2	38.5	3.5	32.9	44.3
Middle finger length	53.8	4.5	47.2	61.3	53.6	4.1	47.0	60.5
Index finger breadth, proximal	14.3	1.4	12.1	16.5	13.8	1.3	11.7	16.0
Index finger breadth, distal	12.7	1.3	10.8	14.9	12.3	1.2	10.5	14.5

Table 2

The statistical values of hand anthropometric dimensions (7-10 years old) [17]

Dimensions(mm)	Boys (N=1138)				Girls (N=1140)			
	M	SD	P5	P95	M	SD	P5	P95
Hand length	144.2	9.9	128.7	161.9	142.7	10.5	126.3	161.2
Hand breadth at metacarpals	65.5	4.5	58.5	73.2	63.4	4.3	56.6	71.1
Palm length perpendicular	82.3	6.0	72.8	92.8	80.7	6.2	70.8	91.8
Index finger length	56.0	4.4	49.0	63.8	56.2	4.6	48.9	64.2
Thumb length	45.9	4.0	39.9	52.9	45.9	4.3	39.1	53.4
Middle finger length	62.4	4.8	54.9	70.8	62.6	5.0	54.9	71.5
Index finger breadth, proximal	15.7	1.3	13.6	18.0	15.1	1.3	13.1	17.4
Index finger breadth, distal	14.1	1.2	12.2	16.3	13.6	1.1	11.9	15.7

The data is then substituted into Eq. (3) to determine the optimum handlebar size for average children.

$$\text{Optimal handle diameter} = \text{Inside grip breadth} - \frac{0.133 \times \text{hand length}}{\pi} \quad (4)$$

$$= 30 - \frac{0.133 \times 120}{\pi} \quad (5)$$

$$= 24.92 \text{ mm @ } 2.49 \text{ cm} \quad (6)$$

3. System Framework and Design

3.1 3D Printing of Bicycle Handlebar

The handlebar of the instrumented bicycle is customized to include the usage of a load cell to measure handgrip strength and a heart rate sensor to detect the heart rate value of a person. A study conducted by Kern *et al.*, [18] found out that the severity of the disorder is correlated with the strength of the handgrip in which the weaker the handgrip strength, the more severe the disorder is. Hence, there is a need to implement a handgrip measurement in the monitoring system for the purpose of evaluating ASD children severity. One of the other crucial parameters that determines the fitness of the human health is heartrate measurement [19].

SolidWorks program is used for the 3D CAD designing process to fit these electronics' components into a compact handlebar that can be attached to the bicycle. The file is then saved into STL formatted and exported to the 3D printers using a slicing program called Ultimaker Cura. After slicing the CAD model, a G-code file is created and sent to the printer to begin printing.

The extruder was set at a temperature of 200°C and the printing bed at 105°C. The 3D model is printed in a default fill pattern called "Rectilinear", a printing method that prints two adjacent layers with an alternating angle of 90°. The layer height was set as approximately 0.16 mm, and the infill was set as 30%. The details of the equipment, materials, and software that are used to produce the prototype are listed in Table 3 below.

Table 3
Printing material and software details

Detail	Description
Printer	Creality CR-6 SE
Filament material	Polylactic Acid (PLA)
Filament color	Black
Filament print temperature	190°C - 220°C
CAD Software	SolidWorks
Slicing software	Ultimaker Cura

The engineering drawing of the 3D model and its dimension can be seen in the Figure 2 to 5 below.



Fig. 2. SolidWorks Model of the Handlebar



Fig. 3. 3D Printed Handlebar

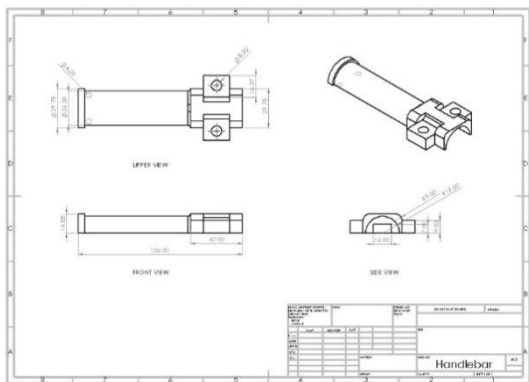

Fig. 4. Engineering Drawing of the 3D Printed Handlebar



Fig. 5. Assembly of 3D Printed Handlebar on Hotaru Balance Bike

3.2 Sensors and Electronics Configuration

The handlebar module of the instrumented bicycle incorporates two types of sensors: a load cell to detect the children's handgrip forces and a pulse sensor to detect the heart rate while gliding the bike. The sensors are connected to a microcontroller unit, namely a TTGO display with built-in ESP32 to capture the data obtained from the sensors and present it in numerical and graph displays. The microcontroller is programmed to process the data in a fuzzy-logic module to detect the heart rate and hand grip strength. Figure 6 and Figure 7 shows the diagram that shows the connection between the electrical devices and sensors.

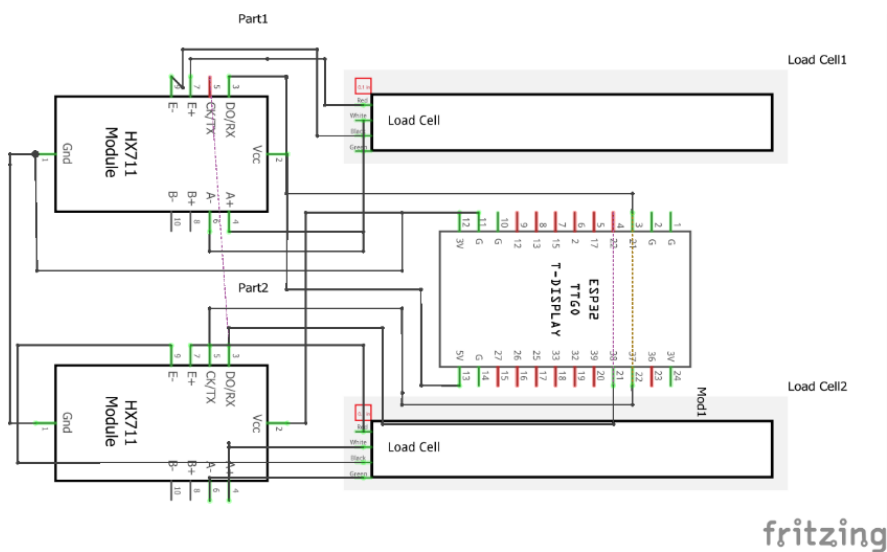
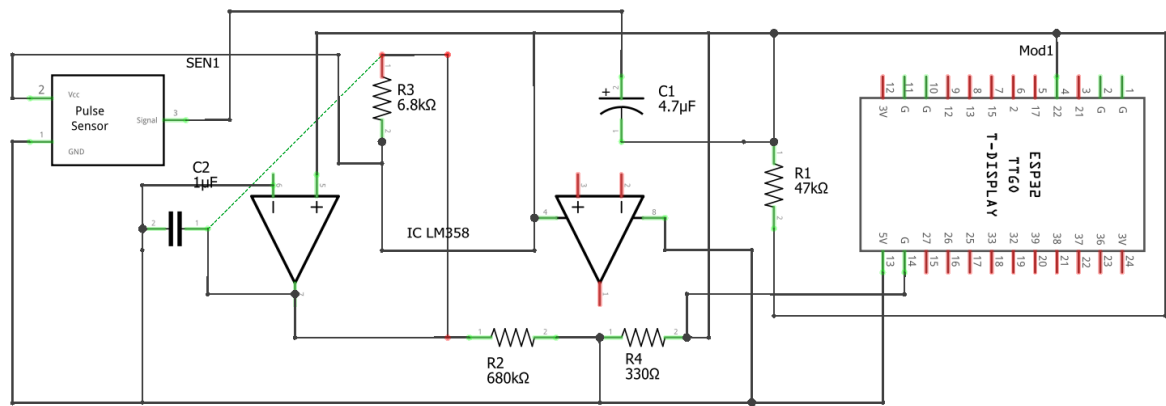

Fig. 6. Circuit Design of Loadcell by using Fritzing software



fritzing

Fig. 7. Circuit Design of heartbeat sensor by using Fritzing software

The microcontroller used for the module is a TTGO display with built-in ESP32, responsible for reading, processing, and sending data from the sensors. The microcontroller is chosen due to its small size and ability to interface with other systems via Wi-Fi through its SPI/SDIO or I2C/UART interfaces. The microcontroller also uses an ultra-low power consumption that fits with the proposed system's purpose, which is to be made as a wireless IoT device and biomechanical device.

The process of measuring the handgrip strength is made possible by using a rectangular load cell. The load cell can detect loads up to a capacity of 20kg. In order to read the signal from the load cell, a general interfacing HX711 driver is used to enable a precise 24-bit analog-to-digital conversion (ADC). The system works with a voltage supply of 2.7 to 5 V and has a straightforward working principle.

The load cell contains two pins that are used to send excitation signals to two sides of the Wheatstone bridge and another two to read the voltage difference on the other side of the bridge. The primary working mechanism of the load cell is when the load cell is in balance or free mode, the voltage difference reading is zero. The voltage difference reading will either increase or decrease when the bridge is unbalanced, in which a situation where a force is applied onto the load cell. The HX711 ADC will then recognize the voltage difference in the unit mV and further undergoes the process of amplification and conversion to digital values, which the microcontroller can read.

3.3 Smart Fi-cycle IoT Website Application

The Smart Fi-cycle IoT website's database design consists of three user modules with three different access permission; the most is the admin, followed by the therapist and patient. The admin role is designed to manage the use of the system, the therapist's role in monitoring and managing information relating to the patient's personal and intervention information, and the patient role is to monitor self-intervention data. Table 4 shows the basic information regarding the software and programming language used in completing the website's development.

Table 4
 Tools and programming language used

Tools / Programming Language	Description
HTML	A common language used for front-end website development to develop web page structure and its content
PHP	A scripting language that is embedded within HTML scripting to allow a dynamic and interactive website
AJAX	A technique incorporating the usage of JavaScript and XML asynchronously to allow data to be sent to the website and updated without needing to reload the whole page
MySQL database	A web-based application or system that enables data from the server to be stored and received
WampServer	A windows web development environment that allows users to create web applications using Apache, PHP, and MySQL database
Atom	A free and open-source text and source code editor that is used to write code for the development of the website
PlantUML	An open-source program that enables the users to create a diagram from plain text language
Gaphor	An application used in modeling UML and SysML to visualize the design of the system architecture and explain the entities within the database module

The data storage purposes for the overall system are using MySQL databases. The connection of every entity within the Smart Fi-cycle is explained through the entity relationship diagram, as shown in Figure 8. The relationship diagram discusses the different permission that could be accessed through a unique primary key. Figure 9 shows the interaction between the module to the database through a sequence diagram to provide a clear understanding of the access permission of each module.

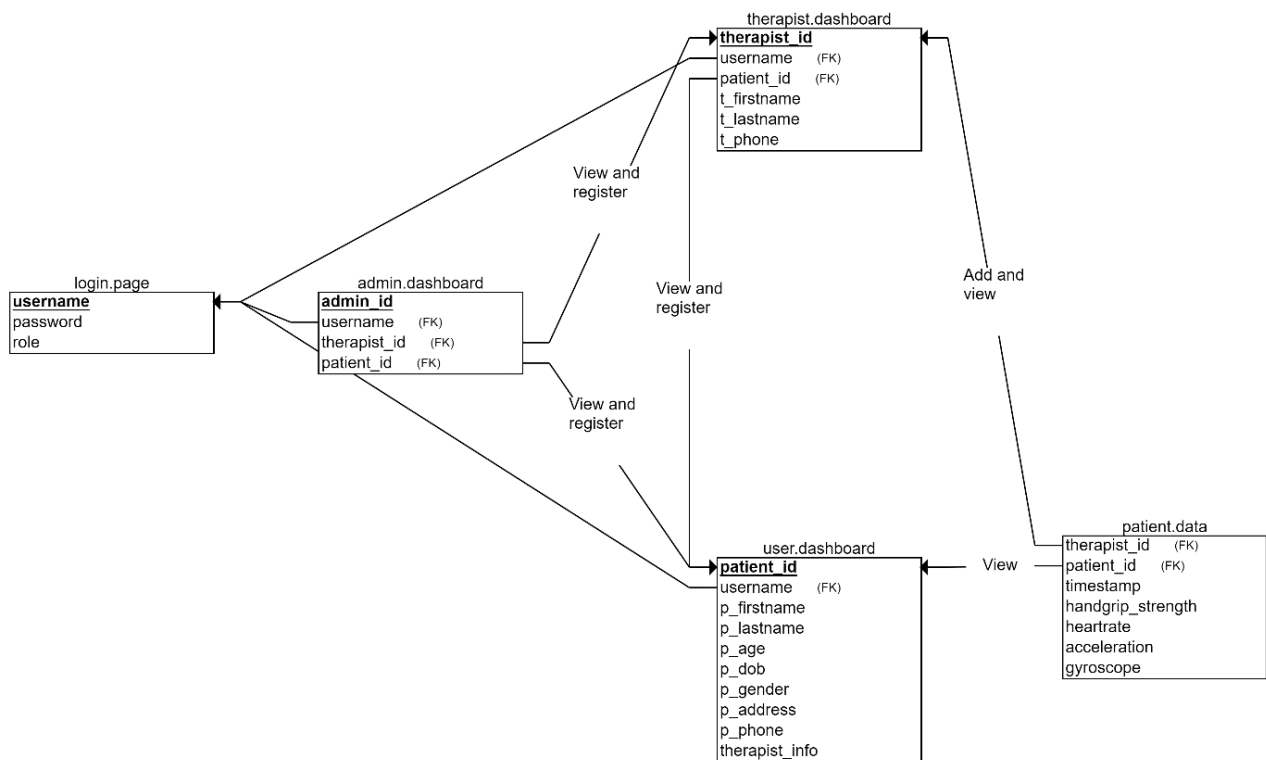

Fig. 8. Entity relationship diagram

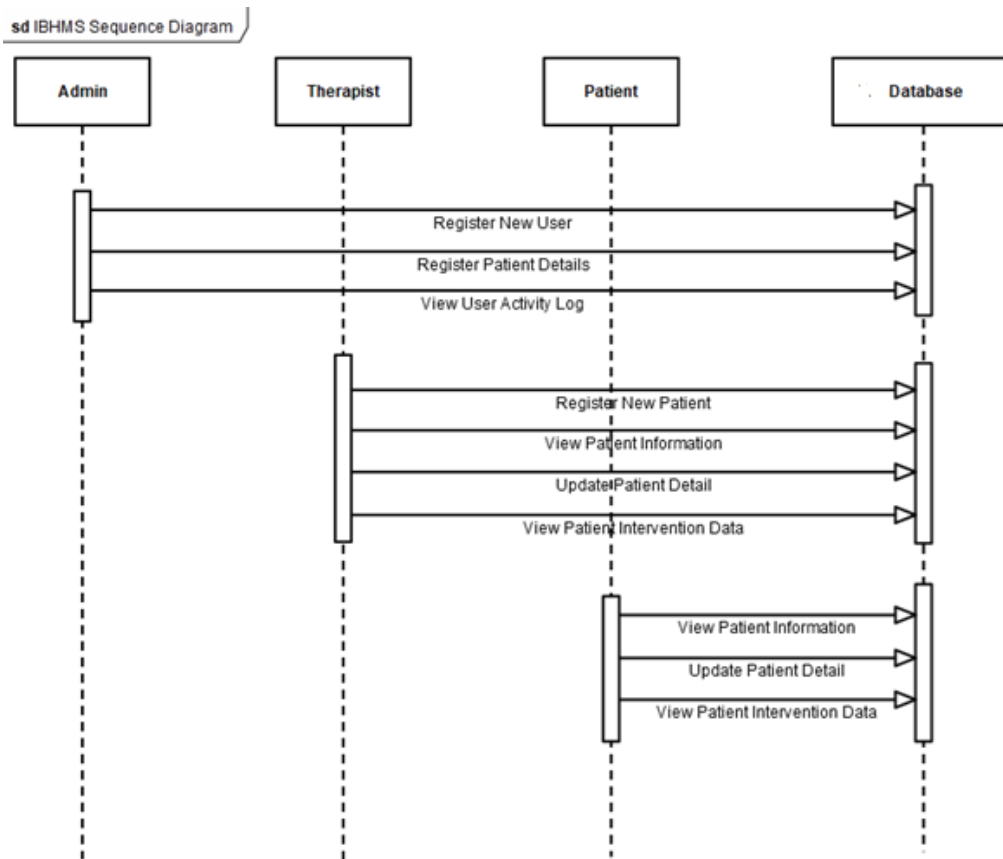

Fig. 9. Smart Fi-cycle website sequence diagram

4. Results and Discussion

4.1 Loadcell Sensor Calibration

The calibration of the load cell can be done by using the open-source Arduino *HX711_ADC* library example code. An example coding file named "*Calibration.ino*" is used to ease the process of obtaining the calibration factor. The detailed step for the process is as in Table 5.

Table 5

Steps of calibrating the load cells

Steps	Description
Step 1	Set the tare value where the loadcell is in a stable condition with no load placed on the sensor
Step 2	Place a known mass to the active area of the sensor and key in the value on the serial monitor
Step 3	Save the calibration value to <i>EEPROM</i> to avoid from having to re-enter the calibration value for every usage
Step 4	Unload the mass and verify the accuracy of the load cell reading by comparing with different known masses

The results of the calibration experiment display the deviation of the value obtained from the load cell with its actual weight and percentage of error as shown in Table 6. Based on the presented result in Table 6, the percentage error is relatively low.

Table 6

Load cell calibration data

Weight (kg)	Result (kg)	Difference (kg)	Error (%)
0.03	0.0308	0.0008	2.67
1.00	1.0130	0.0130	1.30
2.50	2.5021	0.0021	0.08

4.2 Heartrate Sensor Calibration

The heart rate measurement is obtained by performing the heart rate measurement reading comparison on Mi Smart Band 6 (Figure 10) and the heart rate Sensor (Figure 11). This is to ensure the heart rate reading obtained from the sensor is accurate and reliable.

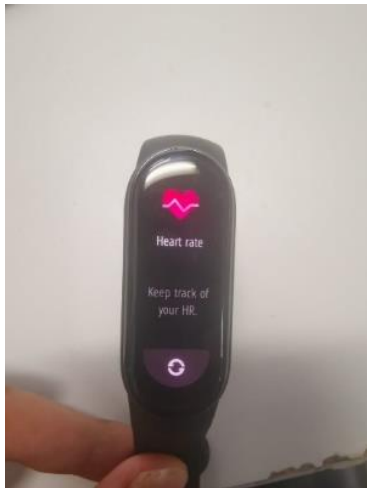

Fig. 10. Mi Smart Band 6 Heart Rate Measurement Feature



Fig. 11. Heartrate on Sensor and Smart Watch is Monitored Simultaneously

The data obtained for the calibration is shown in the Table 7 below with its percentage of error

Table 7

Heartrate sensor calibration data

XD-58C (bpm)	Mi Smart Band 6 (bpm)	Difference (bpm)	Error (%)
62	68	-6	8.82
81	73	8	10.96
66	60	6	10.00

4.3 Smart Fi-cycle IoT Website

The website incorporates several functions that is beneficial in which could help the therapist and the patient to monitor their progress throughout the intervention period. The following Table 8 describes the functions that are designed in the system.

Table 8
 Functions embedded in Smart Fi-cycle website application

No.	Functions	Description	Permission
1.	Login page	The login page protects the data in which only authorized users can see the saved intervention data	All user
2.	User dashboard	The user dashboard is unique to every user in which the system recognized through the assigned role specified by the admin/therapist	All user <i>(different access per role)</i>
3.	Patient registration	Admin and therapist are permitted to add the information of a new patient with a simple click and data fill layout	Admin, therapist
4.	Staff registration	Staff can register a new therapist's information to be added to the database	Admin
5.	Patient database information	Admin and therapist can monitor their patient on a patient management dashboard. The progress of a specific patient can be searched through the search box by typing in their name.	Admin, therapist <i>(edit, view)</i> Patient <i>(self-view only)</i>
6.	Profile update	The profile update functions enable the user to update their information for contact purposes	All user

a. Login Page

The login page acts as a front page for the Smart Fi-cycle system. It provides a security system where users (admin, therapist, and patient) need to key in their credentials (username and password) to access the database. The page did not include the registration function to provide a more secure system in which the upper-class role can only register user.

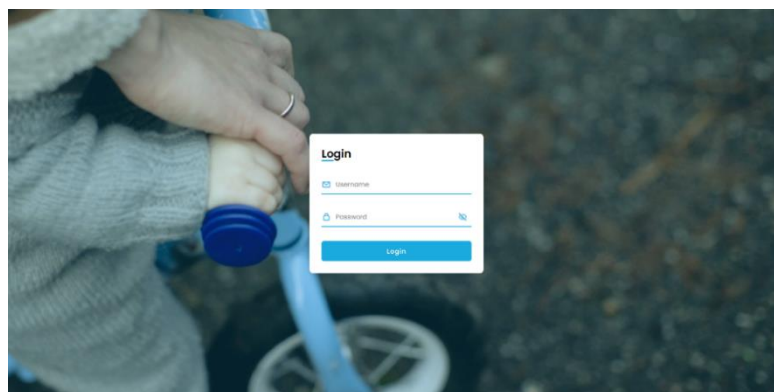

Fig. 12. Admin and user login page

b. User Dashboard

The user dashboard contains two sections; the first section displays the user's information for easier patient identification and contact purposes. The second section is the live monitoring platform, where data from the sensor is shown as a graph in real-time. Data for each session can be obtained by triggering the "Start new session" button to allow the connection of data from the sensor to the webpage in real-time through AJAX. The "Stop current session", on the other hand, is used when the intervention session is done to stop the webpage from receiving data from the sensor.

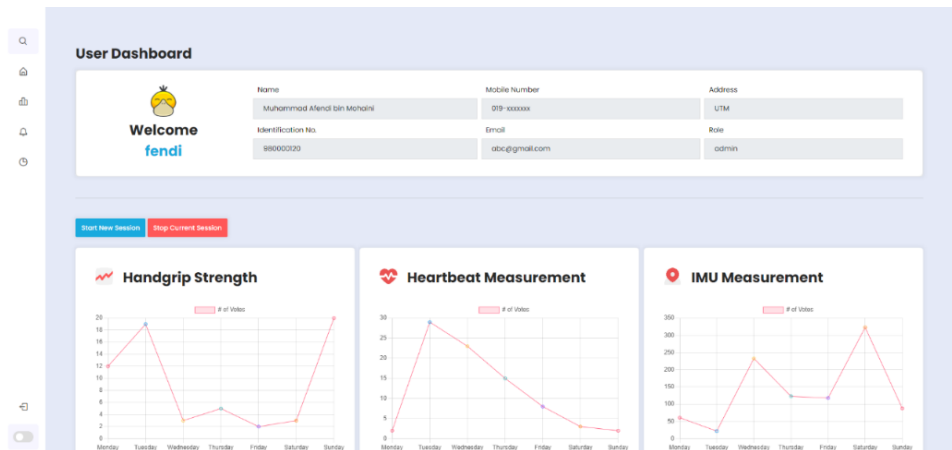

Fig. 13. User dashboard

All data obtained for all intervention sessions are recorded and can be traced back through the table provided under the chart. All data is sorted out by default in the order of timestamp. The system is also incorporating an additional function in which the data can be exported in various file forms (e.g., .csv, .xlsx, .pdf) and print options to ease the work of documentation and analysis.

No.	Timestamp	Handgrip Strength	Heartrate Measurement	IMU Measurement
1	2016/01/16 20:45	2.31	95	0
3	2016/01/23 10:45	1.84	108	0
2	2016/01/31 20:46	5.66	100	0
5	2016/02/18 12:45	4.42	85	0
4	2016/02/26 23:45	0.11	80	0
6	2016/03/17 07:45	6.63	95	0
8	2016/04/19 18:45	2.31	60	0
7	2016/05/28 10:15	1.02	73	0
11	2016/07/09 05:00	0.08	76	0
10	2016/08/12 23:12	2.31	89	0

Fig. 14. Data log on user dashboard

c. Therapist List

The therapist list page is monitored by the admin, in which the details of all therapist is displayed in a table form. The table is equipped with a CRUD function that can be triggered by clicking "Edit" to modify the current information or "Delete" to erase the therapist's data from the database. Registration of a new therapist can be done by clicking the "Add New" button on the upper right corner of the table, which triggers a pop-up form that needs to be filled in, including the login details (username and password).

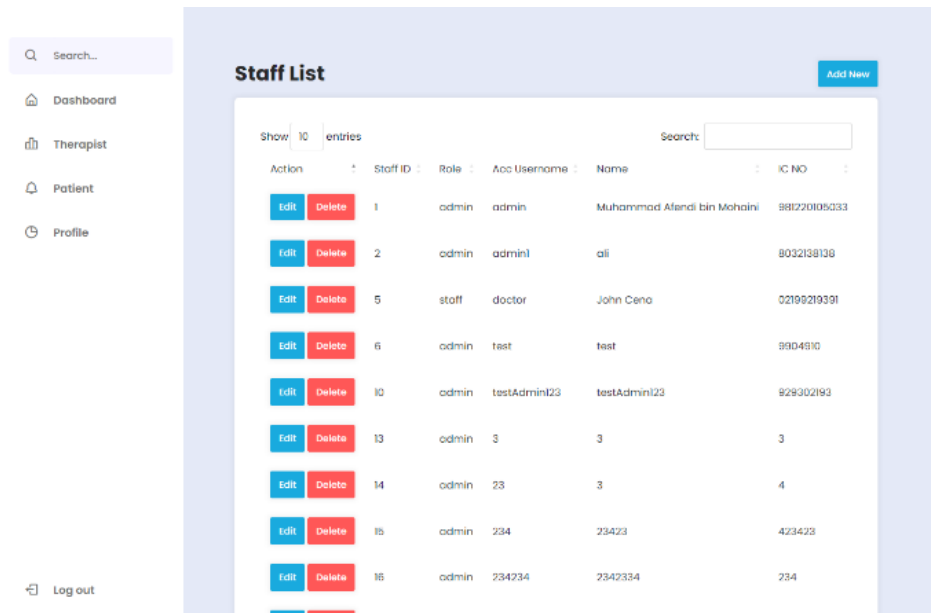

Fig. 15. Therapist list page

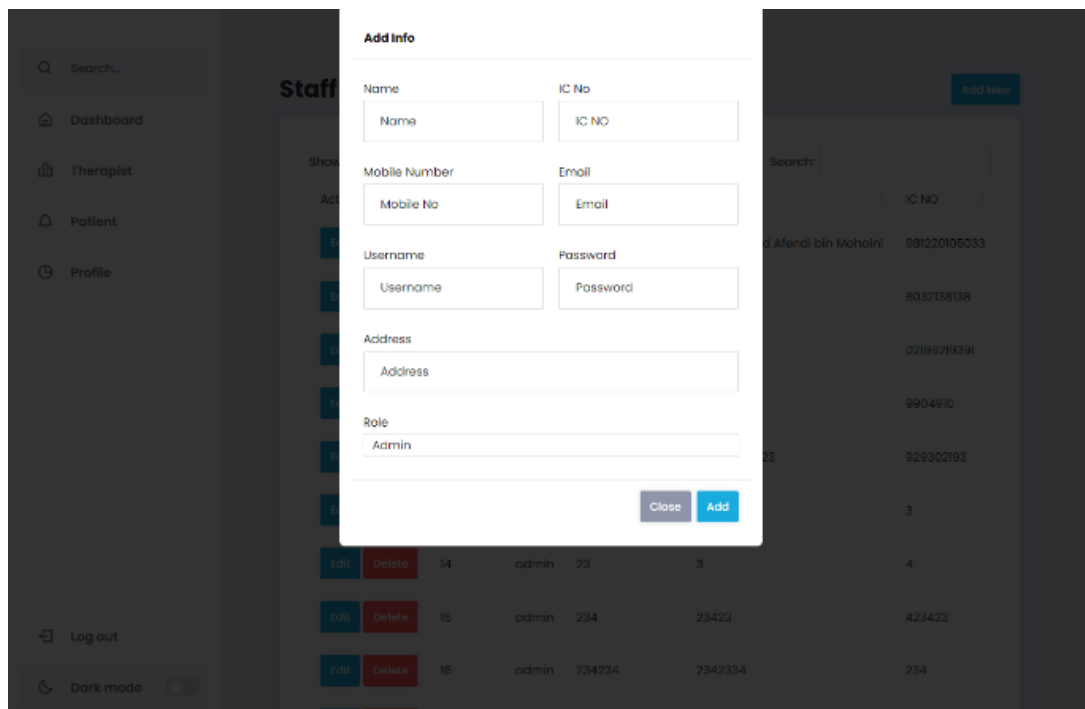

Fig. 16. "Add Therapist" user interface

d. Patient List

The patient list page can be monitored by either admin or therapist, in which all patient details are displayed in the form of a table. The table is equipped with a CRUD function that can be triggered by clicking "Edit" to modify the current information or "Delete" to erase the therapist's data from the database. A new patient can be registered by clicking the "Add New" button on the upper right corner of the table, which triggers a form that needs to be filled in, including the login details (username and password). The table also includes the patient's intervention data to allow the therapist to quickly analyze and monitor the patient's progress.

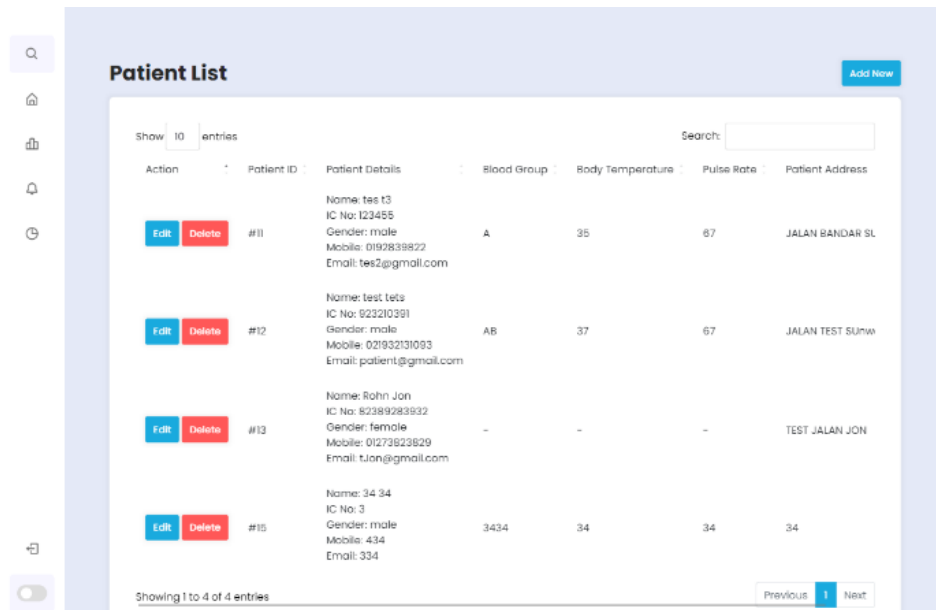

Fig. 17. Patient list page

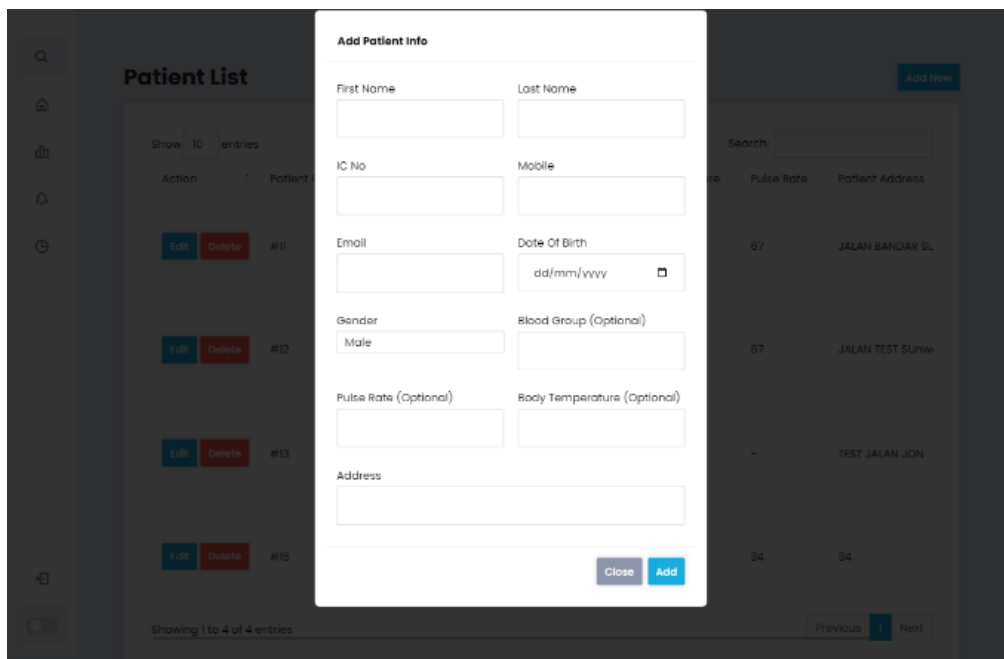

Fig. 18. "Add Patient" user interface

e. Profile Management

The profile management page allows all users to modify their self-information. Users can also change their password information after being randomly assigned by either admin or therapist.

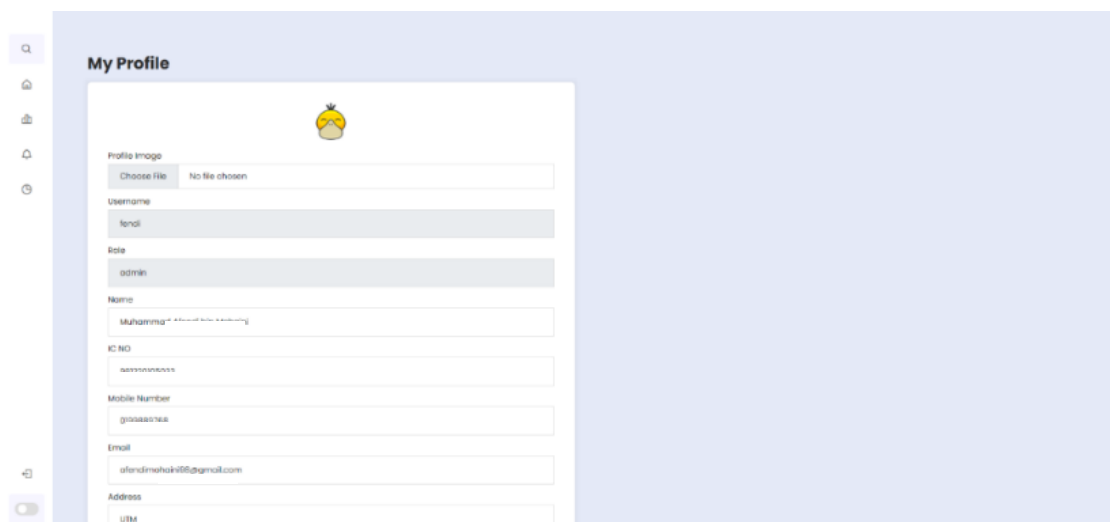

Fig. 19. User information management page

5. Conclusions

In conclusion, an IoT-Based Instrumented Bicycle handlebar is developed by integrating TTGO display with built-in ESP32 and sensors such as loadcells and heart rate sensor. A handlebar with diameter of approximately 30 mm is designed to obtain the handgrip strength. The load cells are able to collect data with percentage error of 0% to 3%. The heartrate sensor on the other hand having data reading with percentage error of 8% to 10%. Further instrumentation could improve the data accuracy and repeatability. Data from the sensors are logged via Wi-Fi in a Smart Fi-cycle IoT Website which is created based on PHP, HTML, and CSS and MySQL databases. Further improvement that can be made to improve the implementation of this system is by using a clinical-grade sensors in detecting physiological measurement and integrating a dedicated webserver to improve data accessibility with higher security.

Acknowledgement

The authors would like to express greatest appreciation to Universiti Teknologi Malaysia (UTM) for supporting this project under grant number Q.J130000.3851.18J86.

References

- [1] Ricciardi, Walter. "Assessing the impact of digital transformation of health services: Opinion by the Expert Panel on Effective Ways of Investing in Health (EXPH)." *European Journal of Public Health* 29, no. Supplement_4 (2019): ckz185-769. <https://doi.org/10.1093/eurpub/ckz185.769>
- [2] Hyman, Susan L., Susan E. Levy, Scott M. Myers, Dennis Z. Kuo, Susan Apkon, Lynn F. Davidson, Kathryn A. Ellerbeck et al. "Identification, evaluation, and management of children with autism spectrum disorder." *Pediatrics* 145, no. 1 (2020). <https://doi.org/10.1542/peds.2019-3447>
- [3] Chen, Li-Chiou, Wan-Chun Su, Tzu-Lin Ho, Lu Lu, Wen-Che Tsai, Yen-Nan Chiu, and Suh-Fang Jeng. "Postural control and interceptive skills in children with autism spectrum disorder." *Physical Therapy* 99, no. 9 (2019): 1231-1241. <https://doi.org/10.1093/ptj/pzz084>.
- [4] Stins, John F., and Claudia Emck. "Balance performance in autism: A brief overview." *Frontiers in psychology* 9 (2018): 901. <https://doi.org/10.3389/fpsyg.2018.00901>
- [5] "Management of Severe Early Childhood Caries - Ministry of Health." Accessed 2023. <https://www.moh.gov.my/moh/attachments/8298.pdf>.
- [6] Shim, Andrew L., Sean Peterson, and Jan Turbes. "Incorporating a Pedal-less Bicycle Curriculum into a K-5th Grade After-school Program to Improve Stability for ASD Children: Editor: Ferman Konukman." *Journal of Physical Education, Recreation & Dance* 87, no. 3 (2016): 52-54. <https://doi.org/10.1080/07303084.2016.1131555>

- [7] Gadsby, April, and Kari Watkins. "Instrumented bikes and their use in studies on transportation behaviour, safety, and maintenance." *Transport reviews* 40, no. 6 (2020): 774-795. <https://doi.org/10.1080/01441647.2020.1769227>
- [8] Ahmad, Nur Irwany, Mohamad Syafiq Mohd Rafi, Diyaa Hidayah Abd Rahman, Nazrul Azril Nazlan, Wan Azani Mustafa, Habibah Mokhtaruddin, Nurhafiza Azizan, and Norhanisa Kimpol. "Monitoring and Controlling Water Pumping System Using IoT for Agriculture Purpose." *Journal Of Advanced Research In Applied Mechanics* 62, no. 1 (2019): 1-15.
- [9] Healy, Sean, Iva Obrusnikova, and Nancy Getchell. "Fundamental motor skill interventions in children with autism spectrum disorder: A systematic review of the literature including a methodological quality assessment." *Research in Autism Spectrum Disorders* 81 (2021): 101717. <https://doi.org/10.1016/j.rasd.2020.101717>
- [10] Colombo-Dougovito, Andrew M., and Martin E. Block. "Fundamental motor skill interventions for children and adolescents on the autism spectrum: A literature review." *Review Journal of Autism and Developmental Disorders* 6 (2019): 159-171. <https://doi.org/10.1007/s40489-019-00161-2>
- [11] Ranky, Richard G., Mark L. Sivak, Jeffrey A. Lewis, Venkata K. Gade, Judith E. Deutsch, and Constantinos Mavroidis. "Modular mechatronic system for stationary bicycles interfaced with virtual environment for rehabilitation." *Journal of neuroengineering and rehabilitation* 11, no. 1 (2014): 1-16. <https://doi.org/10.1186/1743-0003-11-93>
- [12] Seo, Na Jin, Thomas J. Armstrong, James A. Ashton-Miller, and Don B. Chaffin. "The effect of torque direction and cylindrical handle diameter on the coupling between the hand and a cylindrical handle." *Journal of biomechanics* 40, no. 14 (2007): 3236-3243. <https://doi.org/10.1016/j.jbiomech.2007.04.023>
- [13] Esposito, Daniele, Sergio Savino, Chiara Cosenza, Emilio Andreozzi, Gaetano Dario Gargiulo, Caitlin Polley, Giuseppe Cesarelli, Giovanni D'Addio, and Paolo Bifulco. "Evaluation of grip force and energy efficiency of the "Federica" Hand." *Machines* 9, no. 2 (2021): 25. <https://doi.org/10.3390/machines9020025>
- [14] Seo, Na Jin, Thomas J. Armstrong, James A. Ashton-Miller, and Don B. Chaffin. "The effect of torque direction and cylindrical handle diameter on the coupling between the hand and a cylindrical handle." *Journal of biomechanics* 40, no. 14 (2007): 3236-3243. <https://doi.org/10.1016/j.jbiomech.2007.04.023>
- [15] Seo, Na Jin, and Thomas J. Armstrong. "Investigation of grip force, normal force, contact area, hand size, and handle size for cylindrical handles." *Human Factors* 50, no. 5 (2008): 734-744. <https://doi.org/10.1518/001872008x354192>
- [16] Harih, Gregor, and Bojan Dolšak. "Comparison of subjective comfort ratings between anatomically shaped and cylindrical handles." *Applied ergonomics* 45, no. 4 (2014): 943-954. <https://doi.org/10.1016/j.apergo.2013.11.011>
- [17] Ran, Linghua, Xin Zhang, Chuzhi Chao, Taijie Liu, and Tingting Dong. "Anthropometric measurement of the hands of Chinese children." In *Digital Human Modeling: Second International Conference, ICDHM 2009, Held as Part of HCI International 2009, San Diego, CA, USA, July 19-24, 2009. Proceedings 2*, pp. 46-54. Springer Berlin Heidelberg, 2009. https://doi.org/10.1007/978-3-642-02809-0_6
- [18] Kern, Janet K., David A. Geier, James B. Adams, Melissa R. Troutman, Georgia A. Davis, Paul G. King, and Mark R. Geier. "Handgrip strength in autism spectrum disorder compared with controls." *The Journal of Strength & Conditioning Research* 27, no. 8 (2013): 2277-2281. <https://doi.org/10.1519/jsc.0b013e31827de068>.
- [19] Lee, Sangyoung, Young-Deok Park, Young-Joo Suh, and Seokseong Jeon. "Design and implementation of monitoring system for breathing and heart rate pattern using WiFi signals." In *2018 15th IEEE Annual Consumer Communications & Networking Conference (CCNC)*, pp. 1-7. IEEE, 2018. <https://doi.org/10.1109/ccnc.2018.8319181>.