



CFD Letters

Journal homepage:

https://semarakilmu.com.my/journals/index.php/CFD_Letters/index

ISSN: 2180-1363



CFD Investigation on The Jet-Engine Inspired Wind Turbine

Nur Shamimi Amirah Md Sunhazim¹, Fazila Mohd Zawawi^{1,*}, Ummikalsom Abidin¹, Syahrullail Samion¹, Kamarulafizam Ismail², Ainaa Maya Munira Ismail³

¹ Department of Thermofluids, School of Mechanical Engineering, Faculty of Engineering, Universiti Teknologi Malaysia, 81310 Skudai Johor, Malaysia

² Department of Applied Mechanics and Design, School of Mechanical Engineering, Faculty of Engineering, Universiti Teknologi Malaysia, 81310 Skudai Johor, Malaysia

³ Department of Thermofluids, School of Mechanical Engineering, Faculty of Engineering, Universiti Teknologi MARA, 81750 Bandar Seri Alam, Masai Johor, Malaysia

ARTICLE INFO

Article history:

Received 25 December 2021

Received in revised form 7 February 2022

Accepted 8 February 2022

Available online 24 February 2022

Keywords:

Jet-Engine inspired Wind Turbine;
Computational Fluid Dynamics (CFD);
curly-shaped shroud; power coefficient

ABSTRACT

The Malaysian Government has set a more ambitious target to achieve higher penetration of Renewable Energy (RE) in the Malaysian energy mix which was 31% by 2025. Compared to the penetration of solar and wind power specifically in the European region, whose sharing was more than 50% of total generation, Malaysia currently only has 2% of its energy coming from RE generation sources, which mostly was provided by solar photovoltaic. In Malaysia's energy sources point of view, wind RE-based power generation system was foreseen a promising potential provided the technology was suitably designed for low wind conditions. Therefore, the potentiality of the Jet-Engine inspired Wind Turbine operating under low-speed wind environment by mean of Computational Fluid Dynamics (CFD) numerical approach were explored in This study. The main objectives were to develop a reliable numerical model for accessing the capability of the Jet-Engine inspired Wind Turbine and to regulate its performance with influence of curly shroud on the induced flow. The conventional shrouded Wind Turbine has been modified which consist of a stator and a rotor blade covered by curly-shaped shroud adapting the concept of Jet-Engine. A constant wind speed of 5 m/s which was the average wind speed in Malaysia, and tip speed ratio (TSR) varies from 2 to 6 were specified in the simulation. The investigation discovered that the curly-shaped shroud gave an impact to the performance of the Wind Turbine as it can be reviewed from the comparison of the power coefficient on the Jet-Engine inspired Wind Turbine with shroud and without shroud. It was found that the shrouded Wind Turbine improved the power coefficient by 8.6% which was from 0.35 to 0.38. The effect of the curly shroud was also analysed by obtained the velocity and pressure contour from the ANSYS Fluent, where there was a swirl formation at the shroud as the air mixed at different angle, which causes the pressure drop and inlet velocity increased.

* Corresponding author.

E-mail address: fazilamz@utm.my (Fazila Mohd Zawawi)

<https://doi.org/10.37934/cfdl.4.2.7280>

1. Introduction

Renewable energy was extensively commercialized in these recent days because of it can replenished naturally and does not have limited supplies compared to non-renewable energy. geothermal. There were a few collective renewable energies used such as solar, wind, water (hydro), biomass, and comparing all these renewable energies, excluding the effect of the installation and ground works, wind energy was the cleanest energy, as it does not produce any CO₂ emissions in situ [1, 2]. This means that wind energy contributes relatively very slightly to the greenhouse effect and help to reduce global warming and devastating climate change unlike fossil fuels that need to be burned to generate significant amounts of energy [3]. The wind energy can be converted into electrical or mechanical engineering

Various investigation has been carried out in order to enhance the performance of the Wind Turbine and to obtain the optimum energy from the wind flow. The recent study was the investigation on the effect of applying shape memory alloys (SMA) wire in the prototype of the Wind Turbine [4]. The SMA wire gives a significant result as the blade that has higher volume fraction of SMA will help in the amplitude ratio reduction due to the increase of blade stiffness properties and the damping property. Based on the effect of geometrical parameters of an optimized Wind Turbine blade in turbulent flow shows the convincing performance results [5]. Power coefficient of optimized geometry 13.7% greater than based geometry. It was agreed that the performance Wind Turbine were depends on two main factors which were wind flow conditions and Wind Turbine design. Hence, Wind Turbine on the market shows a variety of innovative concepts combined with proven technology for both generators and power electronics [6].

The performance of the Wind Turbine by designing the Wind Turbine with a shroud has been developed. By using an experimental and numerical method, it shows a good agreement of the shrouded effect. The power output produced from the Wind Turbine with flange, called wind-lens Wind Turbine, produced more power contrasted to the conventional one for both approaches [7]. Shrouded brims around convention Wind Turbine gave significant power coefficient increased [8]. From the experimental study of shrouded micro-Wind Turbine [9] obtained that the shrouding micro-Wind Turbine not only improves performance but also points out how diffuser geometrical features Length diffuser and flange height can be used to design a turbine with performance curve to suit the location. From exploration [10] shows that the performance increased by 1.6 to 1.7 times than the conventional Wind Turbine. Furthermore, according to numerical study and design optimization of brimmed diffuser-wind lens around Wind Turbine [11], the present diffuser induces wake formation and significantly increase in mass flowrate available for the flow Wind Turbine. Moreover, articulating the pitch angle of turbine blades in conjunction with adjustable nozzle vanes can improve performance by keeping flow incidence angles within the optimum range of a gas turbine engine under all operating conditions [12].

Therefore, the potential of the Jet-Engine inspired Wind Turbine in boosting power generation and its corresponding performance were investigated. Thus, a numerical analysis using Computational Fluid Dynamics (CFD) was carried out. The power coefficients of the Jet-Engine inspired Wind Turbine with and without shroud were compared. The simulation used a wind speed of 5 m/s, which represents the average wind speed in Malaysia, and a tip speed ratio (TSR) ranging from 2 to 6.

2. Methodology

2.1 Jet-Engine Inspired Wind Turbine Modelling

The jet-engine inspired Wind Turbine, as shown in Figure 1, was employed as the baseline model for the research analysis and designed using Computer Aided Design Commercial Software, SolidWorks V27. The comprehensive dimension of the Wind Turbine was shown in Table 1. The Wind Turbine was composed of a stator, a rotor, and two curly shrouds of varying diameters. The curly shroud was designed in such a way that it has capability to enhance the performance of the Wind Turbine due to the vortex formation at the back of the Wind Turbine.

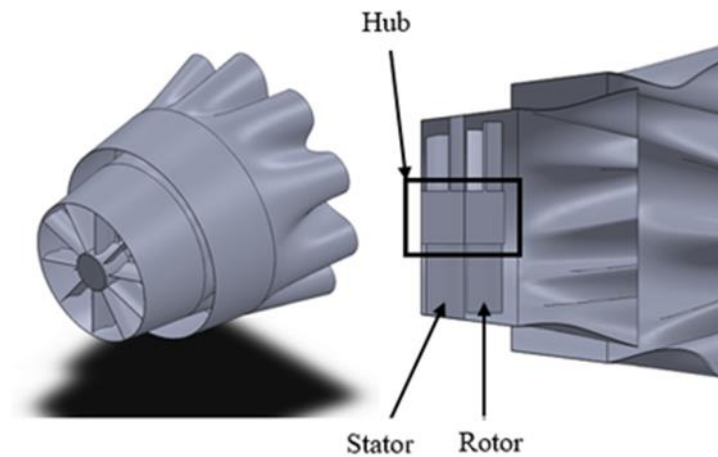

Fig. 1. Isometric and side view of the jet-engine inspired Wind Turbine concept [13]

Table 1

Specifications on the jet-engine inspired Wind Turbine

| Part | Specifications |
|----------------------|-------------------|
| Rotor | Length: 550 mm |
| Stator | Length: 605.09 mm |
| Hub | R220 mm |
| Curly Shroud (Large) | ~ R1215 mm |
| Curly Shroud (Small) | ~ R900 mm |

The computational domain constructed by using Design Modeller in ANSYS Fluent. Two cylindrical domains were created which were rotating and stationary domain, as illustrated in Figure 2. The rotating domain was drawn around the rotor as it was the only part that was rotating, while the stationary domain acts as an enclosure for the fluid to flow. The boundary conditions were specified where the front part was set to be the inlet and the back part of stationary domain was that to be the outlet.

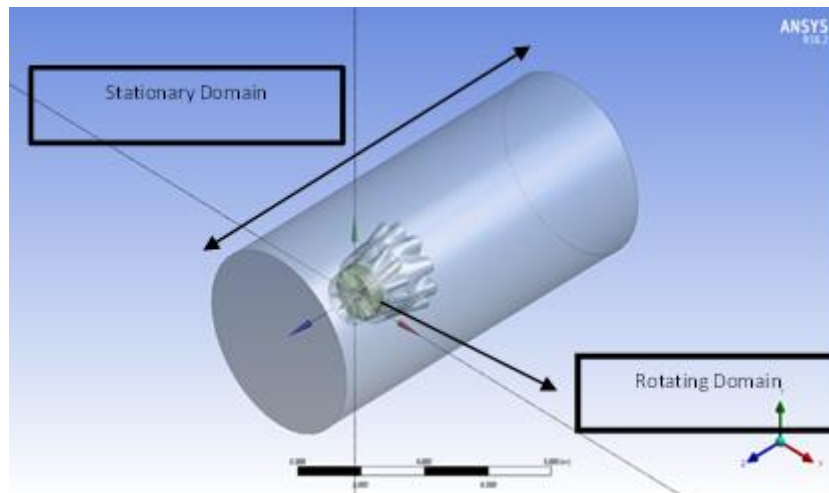

Fig. 2. Numerical domain on the jet-engine inspired Wind Turbine

2.2 Meshing Grid and Boundary Conditions

Meshing grid used in This study was tetrahedral mesh with sizing method. The sizing method was used to refine the mesh grid and reduce the skewness. This will help to reduce the number of elements and time taken for the simulation to be done. For This study, the number of elements was more than 4,000,000. Edge sizing method was used for every edge on the blades and shroud while body sizing method was used for the stationary domain as can be reviewed in Figure 3 and Figure 4.

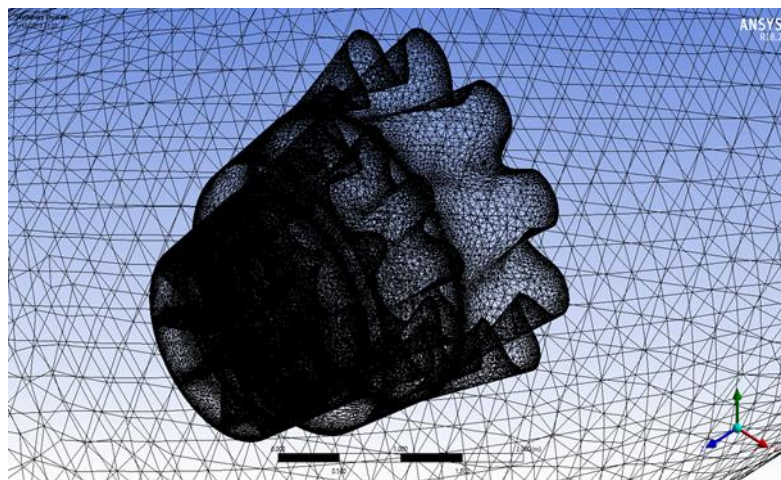

Fig. 3. Edge sizing on the blade and shroud of the jet-engine inspired Wind Turbine

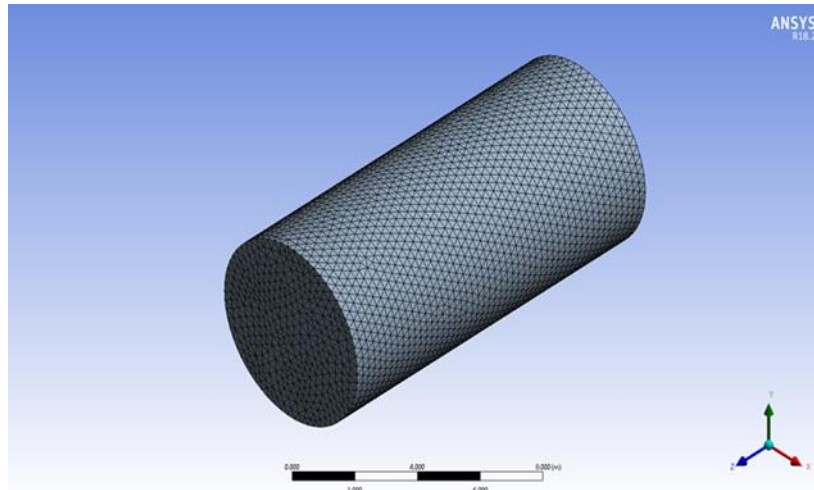

Fig. 4. Body sizing on the jet-engine inspired Wind Turbine

Wind velocity at the intake was set constant at 5 m/s. Meanwhile, the tip speed ratio (TSR) for the Wind Turbine considered for analysis was set between 2 and 6, which was a reasonable range for operating conditions. The TSR value used to determine the Wind Turbine revolutions per minute (RPM). These RPM numbers were entered into ANSYS Fluent during the simulation execution.

2.3 Computational Fluid Dynamics

2.3.1 Turbulence modelling

K-omega Shear Stress Transport (k- ω SST) was applied as turbulence model because of its commonly used to denote a turbulence properties flow. With two additional equations, k- ω SST model was developed to overcome deficiencies of k- ω model. This model more accurate and reliable for wider class of flows than the standard k- ω model. Besides k- ω SST model can perform more precise formulation of the k- ω model in near-wall region [14].

2.3.2 Solution methods

The pressure-velocity coupling setup was set to Semi-Implicit Method for Pressure Linked Equation SIMPLE with skewness correction of 0. This setup was used to convert the continuity equation into a discrete poisson equation for pressure. or the spatial discretization setup, second order upwind was set for the Momentum, Turbulent Kinetic Energy and Specific Dissipation Rate. This was to deduce the link between pressure and velocity in calculating the domain by using a multidimensional linear reconstruction approach.

2.4 Jet-Engine Inspired Wind Turbine Performance

The stagger angle, axial gap, clearance, and the profile of the airfoil (both the stator and rotor profile) all influence the output power of an axial turbine [15]. Consequently, the mechanical power and power coefficient of a wind turbine were calculated to determine its performance. This can be performed by using ANSYS Fluent to retrieve moment values. The power coefficient and mechanical power of the wind turbine were calculated using the equations below.

$$\text{TSR} = \omega R/v \quad (1)$$

$$\text{Available wind power, } P_{in} = \frac{1}{2} AV^3\rho \quad (2)$$

$$\text{Generated mechanical power, } P_{out} = T\omega \quad (3)$$

$$\text{Power coefficient, } C_p = P_{out}/P_{in} \quad (4)$$

where the rotational speed, ω , blade radius, R , wind velocity, v , Wind Turbine swept, A , density of air, ρ and blade torque, T .

3. Result

3.1 Comparison of the Performance

The performance of the wind turbine validated by comparing the values of mechanical power and power coefficient between Jet-Engine inspired Wind Turbine with shroud and without shroud. Thus, the influence of the curly shroud towards the performance of the wind turbine can be studied. By using Equation (2) the value of wind power obtained are 150.1331 W. From illustration in Figure 5 and Figure 6, there is a minor increment between wind turbine with shroud and without shroud. As can be seen in both figures, there is no change of any values when TSR value of 2. Meanwhile, for TSR value of 6, mechanical power was increase from 52.03 W to 56.96 W and the value of power coefficient augmented from 0.35 to 0.38 respectively.

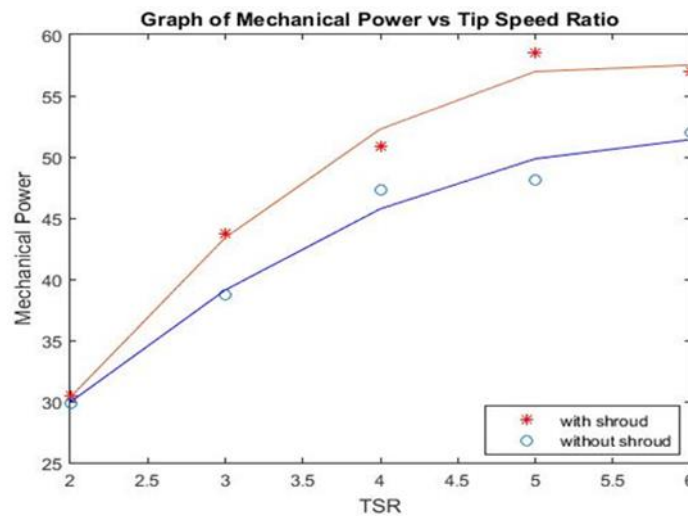

Fig. 5. Comparison on the mechanical power of the wind turbine with and without shroud

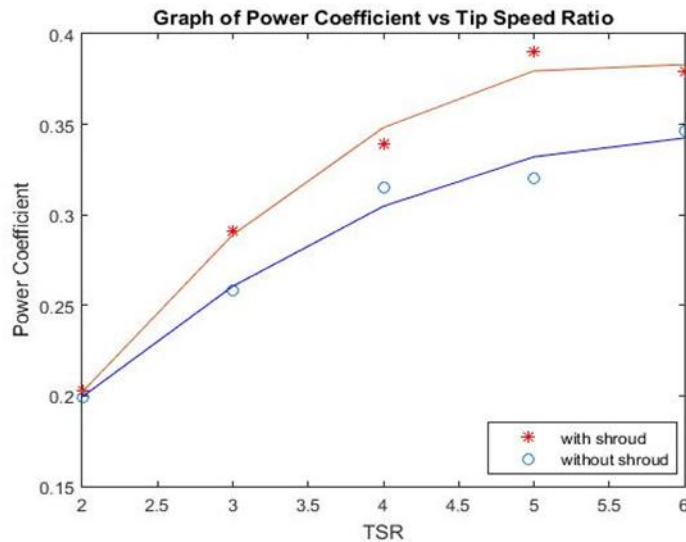

Fig. 6. Comparison on the power coefficient of the wind turbine with and without shroud

3.2 Effect of the Curly Shroud

The effect of the curly shroud on wind turbine performance was also investigated using the contour generated by ANSYS Fluent. As illustrated in Figure 7, swirl phenomena occurred at the top of the shroud. This swirl occurred as the air mixed at various angles. The vortex formation is flanked by two curly shrouds.

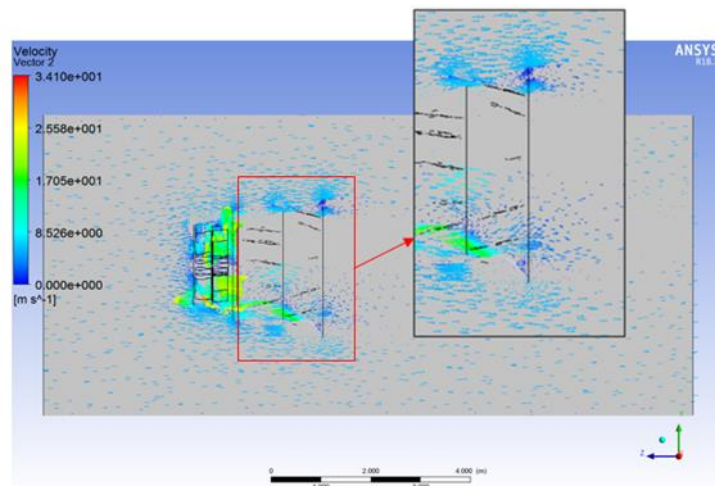

Fig. 7. Vector contour on the wind turbine to capture the swirl formation

Due to this vortex formation, it causes the pressure at the back of the wind turbine to drop. From the pressure contour in Figure 8, it is proven that the pressure was dropped from 0 Pa to -55 Pa. The pressure at the inlet is quite high which is around 50 Pa. This pressure difference will then cause a suction to happen where the high-pressure region will go to low pressure region. This will lead to the increment of the wind speed at the inlet to outlet as Figure 9. The velocity increased from 5 m/s to around 31 m/s. The increment of the velocity at the inlet means that the mass flow rate is increased. This helps to improve the performance of the Jet-Engine inspired Wind Turbine with shroud compared to without shroud.

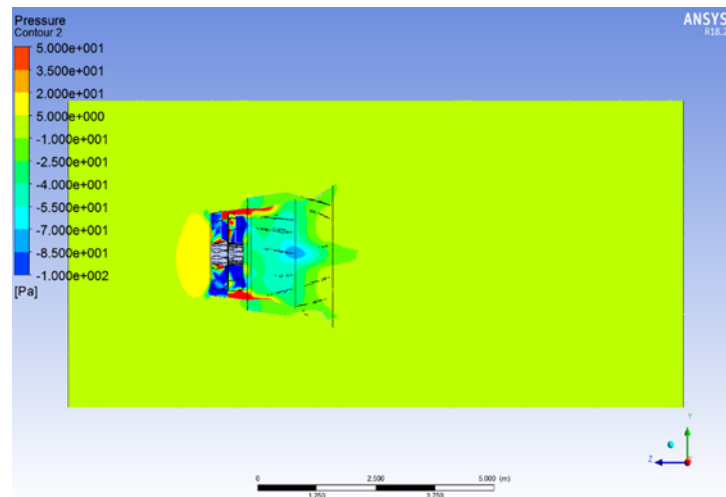

Fig. 8. Pressure contour

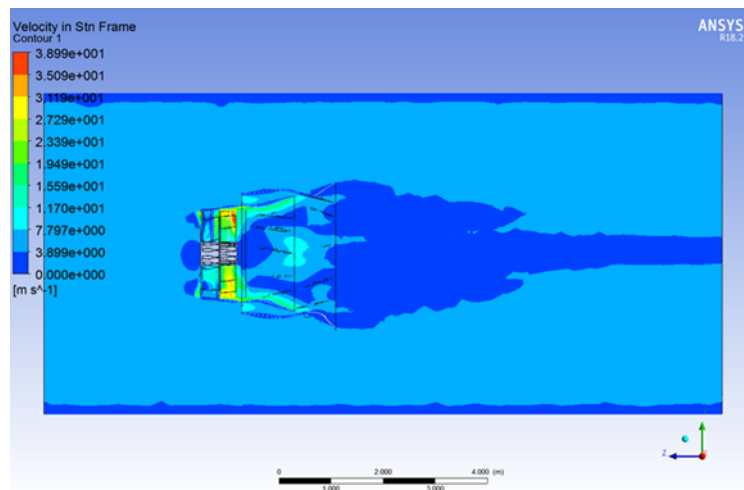

Fig. 9. Velocity contour

3.3 Comparison of the Contour for each TSR Values

For each TSR values, the velocity and pressure values were compared. From Table 2, the velocity at the inlet of the wind turbine is increasing from 13.5 m/s to 31 m/s while for the pressure at the outlet of the wind turbine is from -18 Pa to -80 Pa. This shows that the curly shroud attached on the Jet-Engine inspired Wind Turbine gave a significant increment in the performance of the wind turbine.

Table 2

Comparison of the velocity and pressure values for each TSR values

| TSR | Velocity at the Inlet (m/s) | Pressure at the outlet (Pa) |
|-----|-----------------------------|-----------------------------|
| 2 | 13.5 | -18 |
| 3 | 17 | -45 |
| 4 | 20 | -60 |
| 5 | 26 | -73 |
| 6 | 31 | -80 |

4. Conclusions

The research on Jet-Engine-Inspired Wind Turbines proved that this approach could generate electricity by enhancing the performance of wind turbines. According to the data obtained, a TSR value of 5 yields the highest mechanical power and power coefficient for the wind turbine. The difference in mechanical power and power coefficient values between Wind Turbines with and without shroud implies that the curly shroud influenced the fluid flow at the back of the Wind Turbine. Furthermore, the vortex creation causes a pressure drop at the back of the Wind Turbine, which increases the velocity at the inlet.

Acknowledgement

The authors are grateful to the Universiti Teknologi Malaysia for providing the funding for this study under the Research University Grant (RUG) with a vot number 06G92. The financial support is managed by the Research Management Centre (RMC) Universiti Teknologi Malaysia.

References

- [1] Hansen, M. O. L. "Aerodynamics of Wind Turbines" *Taylor & Francis.3rd Edition* (2015). <https://doi.org/10.4324/9781315769981>
- [2] Schubel, Peter J., and Richard J. Crossley. "Wind turbine blade design." *Energies* 5, no. 9 (2012): 3425-3449. <https://doi.org/10.3390/en5093425>
- [3] Chiras, Dan. *Wind power basics: a green energy guide*. New Society Publishers, 2010.
- [4] Jagadeesh, V., M. Yuvaraja, A. Chandhru, and P. Viswanathan. "Investigations on vibration characteristics of sma embedded horizontal axis wind turbine blade." In *IOP Conference Series: Materials Science and Engineering*, vol. 310, no. 1, p. 012067. IOP Publishing, 2018. <https://doi.org/10.1088/1757-899X/310/1/012067>
- [5] Tahani, M., T. Maeda, N. Babayan, S. Mehrnia, M. Shadmehri, Q. Li, R. Fahimi, and M. Masdari. "Investigating the effect of geometrical parameters of an optimized wind turbine blade in turbulent flow." *Energy conversion and management* 153 (2017): 71-82. <https://doi.org/10.1016/j.enconman.2017.09.073>
- [6] Chen, L., F. L. Ponta, and L. I. Lago. "Perspectives on innovative concepts in wind-power generation." *Energy for sustainable development* 15, no. 4 (2011): 398-410. <https://doi.org/10.1016/j.esd.2011.06.006>
- [7] Ohya, Yuji, and Takashi Karasudani. "A shrouded wind turbine generating high output power with wind-lens technology." *Energies* 3, no. 4 (2010): 634-649. <https://doi.org/10.3390/en3040634>
- [8] Dilimulati, Aierken, Ted Stathopoulos, and Marius Paraschivoiu. "Wind turbine designs for urban applications: A case study of shrouded diffuser casing for turbines." *Journal of Wind Engineering and Industrial Aerodynamics* 175 (2018): 179-192. <https://doi.org/10.1016/j.jweia.2018.01.003>
- [9] Kosasih, Buyung, and Andrea Tondelli. "Experimental study of shrouded micro-wind turbine." *Procedia Engineering* 49 (2012): 92-98. <https://doi.org/10.1016/j.proeng.2012.10.116>
- [10] Bilal Ahmed, Ateeque Ahmed, Ahmad Hussain. "Modelling and Simulation of Diffuser augmented wind turbine" (DAWT). *4th International Conference on Energy, Environment and Sustainable Development* (2016)..
- [11] Govindharajan, Raju, K. M. Parammasivam, and V. Vivel. "Numerical investigation and design optimization of brimmed diffuser-Wind lens around a wind turbine." In *Eighth Asia-Pacific Conference on Wind Engineering*, pp. 1204-1210. 2013. https://doi.org/10.3850/978-981-07-8012-8_202
- [12] Murugan, Muthuvel, Anindya Ghoshal, Fei Xu, Ming-Chen Hsu, Yuri Bazilevs, Luis Bravo, and Kevin Kerner. "Analytical study of articulating turbine rotor blade concept for improved off-design performance of gas turbine engines." *Journal of Engineering for Gas Turbines and Power* 139, no. 10 (2017). <https://doi.org/10.1115/1.4036359>
- [13] Cheraghi, S. Hossein, and Frank Madden. *Next Generation Wind Turbine*. No. DOE-WNEU-0003276. Western New England Univ., Springfield, MA (United States), 2012.
- [14] Carcangiu, Carlo E. "CFD-RANS Study of Horizontal Axis Wind Turbines, Università degli Studi di Cagliari." PhD diss., PhD Dissertation, 2008.
- [15] Adnan, F. Putra, and Firman Hartono. "Design of single stage axial turbine with constant nozzle angle blading for small turbojet." In *Journal of Physics: Conference Series*, vol. 1005, no. 1, p. 012026. IOP Publishing, 2018. <https://doi.org/10.1088/1742-6596/1005/1/012026>